



Correlations Between Personality, Affective and Filial Self-Efficacy Beliefs, and Psychological Well-Being in a Sample of Italian Adolescents

Marco Tommasi, Paola Grassi, Michela Balsamo, and Laura Picconi

Department of Psychological, Health and Territorial Sciences, University of Chieti-Pescara, Italy

Adrian Furnham

Research Department of Clinical, Educational and Health Psychology, University College London, UK; Norwegian Business School (BI), Nydølveien, Oslo, Norway

Aristide Saggino

Department of Psychological, Health and Territorial Sciences, University of Chieti-Pescara, Italy



Psychological Reports

2018, Vol. 121(1) 59–78

© The Author(s) 2017

Reprints and permissions:

sagepub.com/journalsPermissions.nav

DOI: 10.1177/0033294117720698

journals.sagepub.com/home/prx



Abstract

Adolescence is a critical period for the emergence of a balanced personality in adults. Extraversion, neuroticism, and affective self-efficacy beliefs in emotion regulation showed to be good predictors of psychological well-being in adolescents. We analyzed the association between affective self-efficacy beliefs, personality traits, and psychological well-being of 179 Italian adolescents. We also analyzed the connection between adolescents' filial self-efficacy beliefs and psychological well-being and possible moderating effects of self-efficacy beliefs on personality traits. Results show that extraversion, neuroticism, and self-efficacy beliefs in emotion regulation are correlated with psychological well-being, while filial self-efficacy does not. Self-efficacy beliefs do not show significant moderating effects on personality traits, even if self-efficacy beliefs in expressing positive emotions reduce negative characteristics of individuals with high level of psychoticism.

Corresponding Author:

Marco Tommasi, Department of Psychological, Health and Territorial Sciences, University of Chieti-Pescara, Via dei vestini 31, 66100 Chieti, Italy.

Email: marco.tommasi@unich.it

Keywords

Self-efficacy beliefs, adolescence, personality traits, psychological well-being, multiple indicators and multiple causes models

Introduction

The family of origin is very important for successive development of adolescents (Arnett, 2004) and, especially in Italy, the permanence of young people in their families is very long. At the age of 29, 50% of males and 25% females keep living with their parents (Cavalli, 1996). According to the Italian institute for census, in 2015 the percentage of young males and young females (age range 25–29 years) living with their parents has increased to 69.1% and to 54.9%, respectively (www.Istat.it). Due to the long permanence in the family of origin, abilities of adolescents and young adults to establish good relations with their parents should be very important for their psychological well-being. Some studies showed that positive adolescent–parents relations have positive effect on psychological well-being (Ben-Zur, 2003) and that perceived self-efficacy beliefs can affect the quality of the relationships between parents and sons (Caprara, Pastorelli, Regalia, Scabini, & Bandura, 2005). According to Bandura's theory, perceived self-efficacy beliefs are the levels of difficulty in different activities or behaviors that people are certain to overcome. Perceived self-efficacy beliefs are specific to the kind of activity, but they imply the ability of individuals to regulate their behavior by themselves and to find the motivation to pursue their aim, improving, in this way, the efficacy of their acts (Bandura, 1977, 1997).

Life satisfaction and psychological well-being are important elements for a positive youth development (Park, 2004). Therefore, the measurement of psychological well-being and the definition of factors which have an influence on it is an important topic in psychological research on adolescents. In literature, the typical measures of psychological well-being are life satisfaction and happiness (Bradburn, 1969; Ryan & Deci, 2001). Positive emotions and degree of life satisfaction are the primary elements of psychological well-being. However, some psychological studies emphasize other aspects of psychological well-being such as skills in self-fulfillment and positive psychological functioning (Ryan & Deci, 2001; Ryff, 1989).

According to Ryff (1989), positive functioning and self-fulfillment are operationalized and measured by six dimensions: self-acceptance (SA), positive relations with others (PR), autonomy (AU), environmental mastery (EM), purpose in life (PL), and personal growth (PG). All these dimensions generate positive emotions and well-being. SA measures subject's self-actualization and maturity; positive relations measures subject's empathy and ability to create close relationships; AU measures self-determination and independence; EM measures subject's ability in choosing or creating environments suitable to her or his psychic conditions or in taking advantage of environmental opportunities;

PL measures subject's intentionality and ability to set goals in life; and PG measures subject's ability in pursuing her or his own potentials. All these dimensions are all important components of psychological well-being, because they are positively correlated with life satisfaction and positive emotions and negatively correlated with negative emotions (Ryff, 1989).

Psychological well-being is strongly related to personality traits (Steel, Schmidt & Shultz, 2008). In particular, extraversion and neuroticism are positively and negatively correlated with psychological well-being (Ryan & Deci, 2001). DeNeve and Cooper (1999) did a meta-analysis of 197 samples, which included, altogether, more than 40,000 subjects. Results showed that agreeableness and extraversion were positively correlated with psychological well-being, while neuroticism was negatively correlated with it. Diener and Lucas (1999) found that conscientiousness, agreeableness, and openness had the lowest correlations with psychological well-being, while extraversion and neuroticism had the highest correlations with it. They explained the difference suggesting that conscientiousness, agreeableness, and openness are affected by environmental rewards or appreciation, while extraversion and neuroticism are more genetically determined. However, other researchers found that the five factor of personality are largely attributable to genetic and nonshared environmental factors (Vernon, Martin, Aitken Schermer, & Mackie, 2008). In relation to self-fulfillment and psychological functioning, Schmutte and Ryff (1997) found that extraversion, conscientiousness, and low neuroticism were correlated to SA, EM, and PL; openness was correlated to PG; agreeableness and extraversion were correlated to positive relations; and low neuroticism was correlated to AU.

According to the social-cognitive theory of personality (Bandura, 1977, 1997; Caprara & Cervone, 2000; Cervone & Williams, 1992; Mischel, 1973; Mischel & Shoda, 1995), personality is an integrated cognitive-affective system derived from the combination of different psychological processes, which enable individuals to interpret situations and environment, to reflect about their skills and competencies and to self-regulate and plan their actions. On the basis of these processes, people develop beliefs about themselves and their relation to the social environment. Personality traits, therefore, consist not only of innate dispositional tendencies but also of capabilities and self-appraisals, such as self-regulation processes and perceived self-beliefs (Cervone & Shoda, 1999).

Perceived self-beliefs can give reliable prediction of life outcomes over the course of time. Caprara, Steca, Gerbino, Paciello, and Vecchio (2006) showed that adolescent's self-efficacy beliefs to manage positive and negative emotions contribute strongly to perceive a sense of satisfaction for the life, positive emotions, and to maintain a high degree of self-esteem. Other researchers have confirmed that self-efficacy beliefs have positive effects on academic achievement in children (Bandura, Barbaranelli, Caprara, & Pastorelli, 1996), prosocial behaviour of adolescents (Bandura, Caprara, Barbaranelli, Gerbino, & Pastorelli, 2003), and quality of communication between adolescents and parents

(Caprara, Scabini, Barbaranelli, Pastorelli, Regalia, & Bandura, 1998). Caprara, Vecchione, Barbaranelli, and Alessandri (2013) found, on a sample composed by 198 adolescents with age range from 15 to 21 years, that the emotional stability increased with age, and that the increment of perceived self-efficacy in managing negative emotions could predict the growth rate of emotional stability. In addition, they showed that male adolescents had higher growth rate of perceived self-efficacy in managing negative emotions than female adolescents and that gender was not significantly associated with emotional stability and of perceived self-efficacy in expressing positive emotions. These results show that there could be a relation between individual's self-appraisals and emotional stability.

Perceived self-beliefs in managing emotions consist of believing to possess the necessary skills to express positive emotions, as joy and happiness, or to hide or manage negative emotions, as sadness or anger, when interacting with others. Perceived self-beliefs can have, consequently, an effect also on the expression of personality traits, favoring the expression of those traits which facilitate social relations and reducing the expression of those traits which deteriorate social relations. Previous studies showed the existence of conjoint effects of perceived self-efficacy beliefs and personality traits (Judge, Erez, Bono, & Thoresen, 2002; McLaughlin, Moutray, & Muldoon, 2008). De Feyter, Caers, Vigna, and Berings (2012) showed that perceived self-beliefs have moderating effects on the relation between personality traits and academic performance. Caprara, Delle Fratte, and Steca (2002) found that perceived self-beliefs have a greater predictive validity, compared to Big Five factors of personality, on psychological well-being in a large group of adolescents attending high schools.

Perceived filial self-efficacy beliefs (PFSBs) are the adolescent's beliefs to be able to keep a good interaction with his parents, to manage negative emotions toward his parents, and to induce his parents to develop positive opinions about him (Brannen, 2002; Cicognani & Zani, 1999; Noller, 1995; Regalia, Barbaranelli, Pastorelli, & Mazzotti, 1999). Adolescents with a high level of perceived filial self-efficacy are able to communicate with their parents, to express them their inner problems, to manage negative emotions when they have some contrasts with their parents, and to act assertively in such a way that their parents can develop good opinion about their behavior. Many studies showed that perceived beliefs in managing familiar relations are strongly associated with the good functioning of a family (Bandura, 1997; Coleman & Karraker, 1998, 2000)

The principal purpose of our study was to examine the ways perceived self-beliefs, in particular perceived self-beliefs in managing negative and expressing positive emotions and filial perceived self-beliefs, interact with personality traits in shaping psychological well-being in adolescents. According to this principal aim, we wanted to test also the following hypotheses:

1. *Psychological well-being is associated with perceived filial self-efficacy.* Because of the long permanence of Italian adolescents in their families of origin, it is

reasonable to hypothesize that adolescents with a high level of filial self-efficacy can enhance their relationship with parents. If adolescents have a good relationship with their parents, they should also experience a higher well-being. Actually, there are no empirical data about the association between perceived filial self-efficacy and psychological well-being in Italian adolescents.

2. *Psychological well-being is associated with perceived self-efficacy beliefs in expressing and managing emotions.* Many studies showed that self-efficacy beliefs in expressing and managing emotions are correlated with life satisfaction, because the ability to express and manage emotions is related to the improvement of social relations and of individual achievements. Therefore, there should be significant correlations between perceived self-efficacy beliefs in expressing and managing emotions and psychological well-being.
3. *Perceived self-efficacy beliefs moderate the association between personality and psychological well-being.* Research showed that there is a connection between psychological well-being and personality traits and that personality traits are associated to individual's self-appraisals. Therefore, it is reasonable to test if the perceived filial and emotion regulation self-efficacy beliefs have a moderating effect on the relation between personality traits and psychological well-being. For example, self-efficacy beliefs in managing negative emotion can play a significant moderating role for extraverts but not for neurotics. The verification of this hypothesis could have a practical effect: if there is a significant correlation between psychological well-being and personality traits and if perceived self-beliefs have significant moderating effects on this correlation, therefore with an appropriate educational or psychological training it is possible to increase psychological well-being by improving perceived self-beliefs.

Actually, there are no empirical data about the moderating effect of perceived filial and emotion regulation self-efficacy beliefs on the association between perceived filial self-efficacy and psychological well-being in Italian adolescents. To test the moderating effects of perceived self-beliefs on personality, defined by Eysenck's model of personality traits (Eysenck, 1991, 1992), we used the specific scales of perceived self-beliefs in managing positive and negative emotions (Caprara & Gerbino, 2001) and of perceived filial self-efficacy (Caprara, Regalia, & Scabini, 2001). We used Ryff's well-being questionnaire to measure psychological functioning and self-fulfillment in adolescents (Ryff, 1989).

Method

Participants

Participants were 190 adolescents or young adults (15.3% females) with a mean age of 16.97 (SD = 1.49) years (age ranged from 14 to 20 years).

Adolescents were enrolled class by class in a high technical school in a residential community near Bari, which is a big town of the southern part of Italy, after asking permission to the local school manager and to the parents. Adolescents were asked to participate to the research on a voluntary basis. The sample contained families of different socio-economical status: skilled workers, employers, professionals, and local merchants. The percentage of adolescents who accepted to participate was about 46%. All the adolescents who accepted to participate responded to the battery of questionnaires. The questionnaires were completed with the pen and pencil method, under the supervision of the examiner and of the teacher during a pause in school-class. Eleven participants were excluded from the analysis because of a higher number (>10%) of missing responses. Therefore, only 179 questionnaires (15.6% females) could be used for statistical analyses.

Measures

Affective self-efficacy beliefs (Caprara & Gerbino, 2001; Caprara et al., 2006). Adolescents' perceived self-efficacy belief of positive (PSBP) and negative (PSBN) emotions were measured by 15 items concerning adolescents' capacity to manage negative and to express positive emotions. In particular, eight negative affect items assessed adolescents' efficacy beliefs in (a) regulating their affect in the face of threats, anger provocation, and rejection, (b) controlling worrisome ruminations when things go wrong, and (c) calming one-self in presence of taxing situations as well as recovering emotionally after suffering perturbing experiences. The remaining seven positive affect items measured adolescents' efficacy beliefs in expressing affection toward others, getting oneself to express enthusiasm and enjoyment, and feeling satisfaction with personal accomplishments. Participants rated the strength of their self-efficacy beliefs on a 5-point scale ranging from 1 (perceived incapability) to 5 (complete self-assurance in one's capability). The internal consistency of PSBP and PSBN for adolescents was .83 for both the scales (Caprara & Gerbino, 2001). An example of items used in the PSBP scale is: "I can show my happiness when something good happens to me." An example of items used in the PSBN scale is: "I can overcome my anger when rejected by others."

Filial self-efficacy beliefs (Caprara et al., 2005). Adolescents' PFSBs were measured by 16 items assessing adolescents' beliefs in their capabilities to discuss their personal problems with their parents even under difficult circumstances, to express positive feelings and to keep under control negative emotional reactions toward them, to manage stress arising from marital conflicts, and to influence parental attitudes and social practices constructively. Participants rated the strength of their self-efficacy beliefs on a 5-point scale ranging from 1 (perceived incapability) to 7 (complete self-assurance in one's capability). The internal

consistency of the PFSB scale was .90 (Caprara et al., 2001). An example of items used in this scale is: "I talk with my parents about my personal problems."

Eysenck Personality Questionnaire—Short Form (EPQ-SF; Eysenck, Eysenck, & Barrett, 1985). The instrument is the Italian version (Sanavio & Soresi, 1979) of the reduced form of the EPQ. It is composed of 48 items which are grouped into four subscales, three of them measuring personality traits such as extraversion (E), psychoticism (P), neuroticism (N), and one for checking validity (Lie Scale – L). Each item has a dichotomous response ("Yes" or "No") and scoring, for each subscale, is given by the sum of each item score (0: "No"; 1: "Yes"). Internal consistencies are .58, .78, .82, and .74 for the P, E, N, and L scale, respectively (Eysenck et al., 1985; Sanavio & Soresi, 1979). The EPQ-SF is the questionnaire of personality used in the cognitive behavior assessment battery (Sanavio, Bertolotti, Michielin, Vidotto, & Zotti, 2006). We decided to select this questionnaire for his large use in the Italian context. An example of items used in the E scale is: "Do you enjoy meeting new people?" An example of items used in the P scale is: "Do you try not to be rude to people?" An example of items used in the N scale is: "Does your mood often go up and down?" An example of items used in the Lie scale is: "Have you ever cheated at a game?"

Psychological Well-Being Scales (Ryff, 1989). Psychological well-being was measured with the Italian version of Ryff's Well-Being Questionnaire (Ruini, Ottolini, Rafanelli, Ryff, & Fava, 2003). The questionnaire is composed by 84 items divided into six scales: SA, PR, AU, EM, PL, and PG. Participants rated their psychological well-being with a 6-point scale ranging from 1 ("I do not agree") to 6 ("I completely agree"). Scale scores can vary from 14 to 84. Internal consistencies were .93, .91, .86, .90, .90, and .87 for the SA, PR, AU, EM, PL, and PG scale, respectively (Ryff, 1989). An example of items used in the SA scale is: "I like most aspects of my personality." An example of items used in the PR scale is: "People would describe me as a giving person, willing to share my time with others." An example of items used in the AU scale is: "I have confidence in my opinions, even if they are contrary to the general consensus." An example of items used in the EM scale is: "In general, I feel I am in charge of the situation in which I live." An example of items used in the PL scale is: "Some people wander aimlessly through life, but I am not one of them." An example of items used in the PG scale is: "I think it is important to have new experiences that challenge how you think about yourself and the world."

Procedure

In accordance with the Declaration of Helsinki for the ethical principles of research with minors, both parents signed a written consent for each participant, before administering the questionnaires. In addition, we asked and obtained the

permission from the manager of the scholastic district of Bari, who is the responsible for the physical, psychological, and ethical rights of students, according to the Italian law. Participation was voluntary and the information provided was anonymous and confidential. Participants were informed about the place and people who conserved their data. We told parents and adolescents that the collected data would have been used for a research about personality and psychological differences among adolescents.

Statistical analyses

We provided descriptives, correlations, and reliability measures (Cronbach's α) of collected measures.

With regression analyses, we tested the predictive power of personality, perceived self-beliefs, and interactions between personality and perceived self-beliefs on operational measures of psychological well-being.

We controlled the unidimensionality of Ryff's psychological well-being scales with a confirmatory factor analysis. The confirmatory factor analysis can be performed on samples with at least 100 subjects (Gorsuch, 1983; Kline, 1979, p. 40). To test model fit, we estimated the chi square (χ^2), the ratio between χ^2 and its degrees of freedom (χ^2/df), the comparative fit index (CFI), the Tucker–Lewis fit index (TLI), the root mean squared error of approximation (RMSEA) and its 90% confidence interval limits, and the squared root mean residual index (SRMR). Model with an acceptable fit should have $\chi^2/df < 3$, RMSEA $< .08$, and SRMR $< .08$ (Hu & Bentler, 1999; Schermelleh-Engel, Moosbrugger & Müller, 2003). Models with a good fit should have $\chi^2/df < 2$, RMSEA $< .06$, and SRMR $< .05$ (Hu & Bentler, 1999; Schermelleh-Engel, Moosbrugger, & Müller, 2003). Hu and Bentler (1999) recommended a cutoff value of .95 for CFI and TLI. Analyses were performed with M-Plus 7.1 (Muthén & Muthén, 2013).

We analyzed the effect of personality, perceived self-beliefs, and their interactions on the general well-being (GWB) latent variable, with multiple indicators and multiple causes (MIMIC) models, to test the predictive power of each variable and of each interaction on psychological well-being. In this way, it is possible to analyze if the predictive power of personality and perceived self-beliefs is not due to the similarity of operational definitions used to measure latent psychological traits.

Results

Descriptives, correlations, and reliability measures

Table 1 shows descriptives (means and standard deviations), bivariate correlations, and Cronbach's α across personality traits (E, P, and N) and Lie scale (L) measured by EPQ-SF.

Table 1. Descriptives of EPQ-SF scales, bivariate correlations and reliabilities across personality traits and Lie scale.

EPQ-SF scales	Mean	SD	E	P	N	Cronbach's α
E	9.36	2.67				.79
P	3.49	1.89	.13			.50
N	5.44	2.99	-.06	-.10		.76
L	5.72	2.36	-.01	.27**	.12	.61

EPQ-SF: Eysenck Personality Questionnaire—Short Form; E: extraversion; P: psychoticism; N: neuroticism; L: Lie scale; SD: standard deviation.

**Significant at .01 level (two tails).

Table 2. Descriptives of PSBs scales, bivariate correlations and reliabilities across self-efficacy beliefs.

PSBs scales	Mean	SD	PSBP	PSBN	Cronbach's α
PSBP	24.4	5.04			.78
PSBN	27.1	5.05	.12		.61
PFSB	62.7	10.8	.35**	.44**	.81

PSBs: perceived self-efficacy beliefs; PSBP: perceived self-efficacy beliefs in expressing positive emotions; PSBN: perceived self-efficacy beliefs in managing negative emotions; PFSB: perceived filial self-efficacy beliefs; SD: standard deviation.

**Significant at .01 level (2 tails).

Correlations between personality traits are not significant. Only the correlation between psychoticism and the Lie scale is significant. This result is confirmed by another previous study (San Martini, Mazzotti, & Setaro, 1996). According to Kline (Kline, 2000, p. 13), Cronbach's α between .60 and .70 indicate an acceptable level of internal consistency, values between .50 and .60 a poor level of internal consistency and values lower than .50 an unacceptable level of internal consistency. Scale P shows a poor consistency. This scale measures the level of social impairment and discomfort in social relations. Probably, the items content of this scale can generate some embarrassment in adolescents, when they are responding, reducing their reliability. This is also confirmed by the significant, even if low, correlation between the scores of the P and L scale.

Table 2 shows descriptives (means and standard deviations), bivariate correlations, and Cronbach's α across perceived self-efficacy beliefs (PSBP, PSBN, and PFSB).

Affective self-efficacy beliefs scales are not significantly correlated, while they are both correlated with filial self-efficacy beliefs. Table 3 shows descriptives

Table 3. Descriptives of PWB scales, bivariate correlations and reliabilities across the six Ryff's Well-Being Questionnaire scales.

PWB scales	Mean	SD	SA	PR	AU	EM	PL	Cronbach's α
SA	47.7	8.11						.76
PR	49.9	8.12	.54**					.75
AU	47.3	7.44	.47**	.24**				.68
EM	47.8	6.85	.68**	.48**	.46**			.67
PL	48.3	6.94	.67*	.45**	.42**	.66*		.62
PG	49.7	6.76	.49**	.51**	.38**	.55**	.51**	.65

Note: PWB: psychological well-being; SA: self-acceptance; PR: positive relations with others; AU: autonomy; EM: environmental mastery; PL: purpose in life; PG: personal growth; SD: standard deviation.

*Significant at .05 level (2 tails); **Significant at .01 level (2 tails).

(means and standard deviations), bivariate correlations, and Cronbach's α across the six scales of psychological well-being.

All the six scales of psychological well-being are significantly correlated, as confirmed by previous studies (Ryff, 1989; Ruini et al., 2003).

Regression analyses

Table 4 shows standardized coefficients of each psychological well-being scale regressed to personality traits (E, P, and N), self-efficacy beliefs (PSBP, PSBN, and PFSB), and interactions between personality traits and self-efficacy beliefs. The variables included in the interaction terms were centered (Cohen, Cohen, West, & Aiken, 2003).

N, PSBP, and PSBN are the significant predictors of SA. E, P, N, and PSBP are the significant predictors of PR. N, PSBP, PSBN, and PFSB are the significant predictors of AU. E, N, PSBP, PSBP, and PFSB are the significant predictors of Environment mastery. P, N, and PSBP are the significant predictors of PL. E, PSBP, and PSBN are the significant predictors of PG. As regards the product terms, only the products $P \times PSBP$ (for environment mastery and PL) and $N \times PSBN$ (for AU and PG) have significant effects. The standardized coefficients of the product $P \times PSBP$ are all positive, while the standardized coefficients of the product $N \times PSBN$ are all negatives. However, P is significant only for PL ($\beta = -.17$) and N is significant only for AU ($\beta = -.20$). This means that PSBP has a moderating effect on P only for PL. In this case, PSBP inverts the effects of P ($\beta = .17$). PSBN has a moderating effect on N only for AU. In this case, PSBN slightly decreases the negative effects of N on AU ($\beta = -.19$). For all the regression models, the variance inflation factors are lower than 2. A variance inflation factor higher than 10 suggests the existence of multicollinearity (O'Brien, 2007).

Table 4. Regression models of each PWB scale with personality traits (E, P, and N), self-efficacy beliefs (PSBP, PSBN, and PFSB) and product terms of personality and self-efficacy beliefs.

	SA			PR			AU			EM			PL			PG		
	β	t	p	β	t	p	β	t	p	β	t	p	β	t	p	β	t	p
E	.11	1.48	.14	.34	4.92	<.01	.09	1.17	.24	.15	2.04	.04	.15	1.95	.05	.18	2.38	.02
P	.02	.23	.82	-.16	-2.53	.01	.03	.42	.67	.01	.19	.85	-.17	-2.51	.01	-.06	-.92	.36
N	-.25	-3.72	<.01	-.14	-2.26	.02	-.20	-3.01	<.01	-.17	-2.67	.01	-.22	-3.39	<.01	-.05	-.68	.50
PSBN	.16	2.05	.04	.07	1.05	.30	.29	3.85	<.01	.22	3.04	<.01	.08	1.04	.30	.24	3.26	<.01
PSBP	.20	2.67	.01	.24	3.56	<.01	.26	3.49	<.01	.16	2.15	.03	.25	3.47	<.01	.29	4.13	<.01
PFSB	.08	1.01	.31	.13	1.70	.09	-.13	-1.54	.12	.20	2.50	.01	.09	1.09	.27	.00	.02	.99
E × PSBN	.09	1.17	.24	.12	1.63	.10	-.19	-2.45	.01	.05	.69	.49	.07	.87	.39	.00	-.03	.98
E × PSBP	.11	1.57	.12	-.04	-.54	.59	.07	.93	.35	.07	.95	.34	.05	.66	.51	-.01	-.09	.93
E × PFSB	-.15	-1.70	.09	-.02	-.27	.79	.16	1.79	.07	-.05	-.63	.53	-.06	-.72	.48	-.03	-.37	.71
P × PSBN	.02	.20	.84	.08	1.15	.25	.01	.18	.86	-.04	-.51	.61	.05	.66	.51	.10	1.34	.18
P × PSBP	.10	1.42	.16	.09	1.49	.14	.13	1.93	.05	.14	2.22	.03	.17	2.56	.01	.08	1.25	.21
P × PFSB	-.01	-.15	.88	-.04	-.55	.59	-.07	-.93	.35	.05	.67	.50	-.14	-1.90	.06	-.13	-1.87	.06
N × PSBN	-.01	-.17	.86	-.02	-.23	.82	-.19	-2.61	.01	-.08	-1.06	.29	-.08	-1.15	.25	-.20	-2.76	.01
N × PSBP	-.08	-1.15	.25	-.07	-1.11	.27	-.01	-.13	.89	.09	1.25	.21	-.01	-.09	.93	-.08	-1.23	.22
N × PFSB	.11	1.48	.14	.04	.57	.57	.13	1.67	.10	.05	.65	.52	.09	1.19	.23	.01	.09	.93
R ²	.28			.39			.27			.32			.30			.32		
R ² _{adj}	.21			.33			.20			.26			.24			.26		
F	4.60			7.57			4.24			5.50			5.01			5.45		
p	<.01			<.01			<.01			<.01			<.01			<.01		

Note. Standardized beta coefficients (β) with corresponding t and p values are reported. Statistics for model validity are R^2 , F , and corresponding p value. E: extraversion; P: psychoticism; N: neuroticism; PSBP: perceived self-efficacy beliefs in expressing positive emotions; PSBN: perceived self-efficacy beliefs in managing negative emotions; PFSB: perceived filial self-efficacy beliefs. SA: self-acceptance; PR: positive relations with others; AU: autonomy; EM: environmental mastery; PL: purpose in life; PG: personal growth. Significant p values ($<.05$) are in bold types.

Confirmatory factor analysis

A confirmatory factor analysis was performed to test if the six scales of psychological well-being can be grouped into a common latent factor which represents GWB. CFA shows a good fit of the unidimensional model ($\chi^2 = 18.69$, $df = 9$, $p = .03$; $\chi/df = 2.08$; CFI = .98; TLI = .96; RMSEA = .08; 90% RMSEA = .03, .13; SRMR = .03). Therefore, the six psychological well-being scales can be considered as a unidimensional test. This result confirms previous findings (Ryff, 1989; Ruini et al., 2003).

MIMIC analysis

With a MIMIC model, we tested the correlations between personality traits, self-efficacy beliefs, and their interaction with GWB. In the first MIMIC model, all the links between GWB, personality traits (E, P, and N), self-efficacy beliefs (PSBP, PSBN, and PFSB), and their product terms were tested. Figure 1 shows the

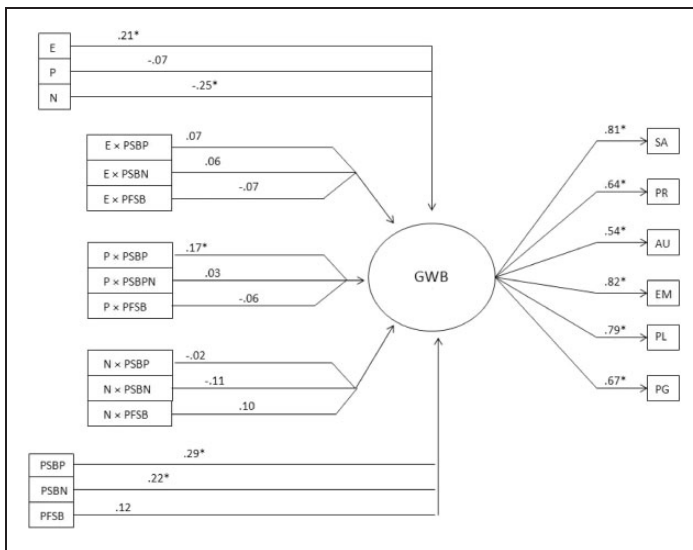

Figure 1. MIMIC model of the relationships between the latent factor GWB, the personality traits E, P, N, the self-efficacy beliefs PSBP, PSBN, PFSB, and their product terms. The R^2 for the prediction of GWB by the manifest variables is .46.

E: extraversion; P: psychoticism; N: neuroticism; PSBP: perceived self-efficacy beliefs in expressing positive emotions; PSBN: perceived self-efficacy beliefs in managing negative emotions; PFSB: perceived filial self-efficacy beliefs; SA: self-acceptance; PR: positive relations with others; AU: autonomy; EM: environmental mastery; PL: purpose in life; PG: personal growth; GWB: general well-being. *Significant at $p < .01$.

path diagram between exogenous covariates, *GWB*, and measures of *GWB*. Coefficients reported in the figure are standardized coefficients. Goodness of fit indexes show that the model has a quite sufficient fit ($\chi^2 = 170.7$, $df = 84$, $p = <.01$; $\chi^2/df = 2.03$; $CFI = .86$; $TLI = .82$; $RMSEA = .08$; $90\% RMSEA = .06, .09$; $SRMR = .04$). Therefore, we created a second MIMIC model by eliminating all exogenous covariates and product terms with not significant links with *GWB*. Only *E*, *N*, *PSBP*, *PSBN*, and the product term $P \times PSBP$ were included as exogenous variables in the MIMIC model. Results show a relevant improvement in model fit ($\chi^2 = 78.11$, $df = 34$, $p = <.01$; $\chi^2/df = 2.30$; $CFI = .92$; $TLI = .90$; $RMSEA = .08$; $90\% RMSEA = .06, .11$; $SRMR = .05$). The χ^2 difference between the former and the latter MIMIC model was $\chi^2_{diff} = 92.59$, with $df = 50$. This difference is significant for $p < .001$. Therefore, *E*, *N*, *PSBP*, and *PSBN* are the best predictors of *GWB*. The strength of this association (Cohen's *d*) was $.43$, $-.52$, $.61$, and $.46$ for the *E*, *N*, *PSBP*, and *PSBN* variable, respectively (Ferguson, 2009). These values indicate a nearly moderate association between the affective self-efficacy beliefs and psychological well-being (Cohen, 1992). Also, the product $P \times PSBP$ has a significant link with *GWB* (standardized $\beta = .15$, $p = .02$, Cohen's $d = .35$). This means that the self-efficacy beliefs in expressing positive emotions favor a positive connection between psychoticism and *GWB*, even if the effect size is small.

Discussion and conclusion

This research confirmed the existence of correlations between personality traits and psychological well-being (Steel et al., 2008). Extraversion affect many dimensions of psychological functioning, in particular *PR*, environment mastery, and *PG*. Extraverts have greater social skills, take more advantages from environmental opportunities, and are more able in pursuing their potentials (DeNeve & Cooper, 1998; Ryan & Deci, 2001). They tend also to be more optimistic and able to obtain social support. Also, neuroticism is correlated with many dimension of psychological well-being. However, all these correlations are negative: neurotics have lower *SA*, less positive relations, lower *AU*, lower environment mastery, and lower *PL*. Therefore, neurotics have stronger problems in reaching self-fulfillment and a good psychological functioning. This can led neurotics to develop passive and negative attitudes towards life, others, and themselves (Ryan & Deci, 2001). Psychoticism is correlated with only few components of psychological well-being. Those who score high on psychoticism are characterized by their impulsivity, egocentricity, and aggressiveness (Eysenck, 1991, 1992). Therefore, their characteristics have more consequences on the quality of their social relationships instead of on the perceived quality of their life. This is confirmed by the significant negative effect of psychoticism on the ability in establishing good relationships with others (Maltby, Macaskill, & Day, 2001).

However, the analyses performed with MIMIC models show that only extraversion and neuroticism affect GWB. This result confirms the strong relation between these personality traits and PWB (DeNeve & Cooper, 1999; Diener & Lucas, 1999; Ryan & Deci, 2001; Schmutte & Ryff, 1997). Probably, this connection is due to the fact that extraversion and neuroticism are partly genetically determined (Diener & Lucas, 1999; Vernon et al., 2008) and are natural predispositions, which determine positive or negative reactions during events of life (Costa & MacCrae, 1980).

As regards our first hypothesis, our results show that filial self-efficacy does not show any relevant association with the components of psychological well-being, except for environment mastery, contrarily to other researches (Ben-Zur, 2003). Probably, among Italian adolescents, relations outside the family of origin have more relevance on psychological functioning. Previous studies found that ability to manage peer pressure toward an antisocial conduct rather more than having positive relations with parents can help adolescents to avoid transgressive conduct (Caprara et al., 1998).

As regards our second hypothesis, this study confirms the existence of an association between the affective self-efficacy beliefs on psychological well-being in adolescents (Caprara & Steca, 2006; Caprara et al., 2002). Self-efficacy beliefs in expressing positive emotions have positive links with all psychological well-being dimensions, while self-efficacy beliefs in managing negative emotions have positive links with SA, AU, environment mastery, and PG. Filial self-efficacy beliefs affect only environment mastery. The MIMIC model confirms that only affective self-efficacy beliefs are significantly connected with psychological well-being, while filial self-efficacy not. People with higher affective self-efficacy beliefs have also greater ability in emotion regulation and in coping negative events (Caprara & Steca, 2002). Some studies have shown that emotion regulation has moderating effect between personality and self-injury in adolescents (Hasking et al., 2010) and that difficulty in emotion regulation is positively related with the severity of borderline symptoms in adolescents (Sharp, Pane, Ha, Venta, Patel, Sturek, & Fonagy, 2011).

As regards our third hypothesis, our results show that self-efficacy beliefs have a very low moderating effect on the association between personality and psychological well-being. Self-efficacy beliefs in expressing positive emotions have moderating effects on psychoticism, and self-efficacy beliefs in managing negative emotions on neuroticism. In particular, self-efficacy beliefs in managing negative emotions tend to attenuate the negative effect of neuroticism on the AU and PG component of psychological well-being, while self-efficacy in expressing positive emotions completely change the association of psychoticism with the EM and PL component of psychological well-being. Psychoticism has a negative effect on positive relations (Maltby et al., 2001). In our study, however, individuals with high psychoticism and high perceived self-efficacy in expressing positive emotions have positive association with environment mastery and PL.

Reasonably, these individuals have a dominant and assertive behavior in pursuing their aims and, concomitantly, are able to establish positive and warm relations with others. From this perspective, the perceived self-efficacy in expressing positive emotions attenuates the negative characteristics of psychoticism. Therefore, “assertive” high P scorers show a better psychological functioning than people with average P scores.

There are not many studies about psychological well-being and its associations with other psychological variables, especially in Italian adolescents. Therefore, psychological well-being, it is still an explorative field of research. In particular, it is not yet clear if there are associations between personality traits, perceived self-efficacy beliefs, and the different components of psychological well-being and how strong are these associations. Our study fills the gap in this sector of studies.

Another question not completely clarified is the interaction between personality traits and self-efficacy beliefs, especially for adolescents. Our study shows that there is a significant correlation between the different components of psychological well-being and personality traits, in particular extraversion and neuroticism, and perceived self-efficacy beliefs, in particular beliefs in managing and expressing emotions. However, personality traits and perceived self-efficacy beliefs are substantially independent of each other. Perceived self-efficacy beliefs have a significant moderating effect only in associations between neuroticism and psychoticism with some components of psychological well-being. The confirmatory factor analysis, using MIMIC models, further confirms that the general factor of the psychological well-being is associated significantly only with extraversion, neuroticism, perceived self-efficacy beliefs in expressing positive emotions, and in managing negative emotions. Surprisingly, perceived filial self-efficacy is not associated with psychological well-being, except for the EM component. Therefore, the adolescents ability to keep a good relation with their parents by reducing negative emotions toward parents and inducing parents to have positive opinions about them is not relevant for their well-being. This result can be partly explained by the fact the behavior of Italian adolescents is strongly affected also by their relations with their peers or with friends that are outside their familiar environment (Caprara et al., 1998), but its complete explanation requires further research.

The limitation of our research is that the sample is not representative of the Italian population of adolescents, but the participation at the research was on a voluntary basis because adolescents were not rewarded. Therefore, it was not possible to reach a high number of participants. Another limitation is that our sample was composed by adolescents living in a specific part of Italy. Further research with more adolescents of different parts of Italy could be done to determine the generalizability of our results.

The principal aim of our study was to find association between personality traits, perceived self-efficacy beliefs, and components of psychological

well-being. Even if this study used a correlation design, however, it found some significant associations between the psychological variables, in particular, between the perceived self-efficacy beliefs and the components of psychological well-being that were never tested before in a sample of adolescents.

Due to strong difference between the number of males and female, we could also not examine the gender differences between adolescents in personality traits and self-efficacy beliefs. Other studies showed significant correlations between gender and personality or self-efficacy beliefs (Caprara & Steca, 2006; Caprara et al., 2013). This was a cross-sectional self-report study and there is always an issue of item overlap between scales as well as not using different methodologies. Nevertheless, we believe it makes a useful contribution to the literature.

Declaration of Conflicting Interests

The author(s) declared no potential conflicts of interest with respect to the research, authorship, and/or publication of this article.

Funding

The author(s) received no financial support for the research, authorship, and/or publication of this article.

References

- Arnett, J. J. (2004). Emerging adulthood: What is it, and what is it good for? *Child Development Perspectives, 1*, 68–73.
- Bandura, A. (1977). Self-efficacy: Toward a unifying theory of behavioural change. *Psychological Review, 84*, 191–215.
- Bandura, A. (1997). *Self-efficacy: The exercise of control*. New York, NY: Freeman.
- Bandura, A., Barbaranelli, C., Caprara, G. V., & Pastorelli, C. (1996). Multifaceted impact of self-efficacy beliefs on academic functioning. *Child Development, 67*, 1206–1222.
- Bandura, A., Caprara, G. V., Barbaranelli, C., Gerbino, M., & Pastorelli, C. (2003). Role of affective self-regulatory efficacy on diverse spheres of psychosocial functioning. *Child Development, 74*, 769–782.
- Ben-Zur, H. (2003). Happy adolescents: The link between subjective well-being, internal resources, and parental factors. *Journal of Youth and Adolescence, 32*, 67–79.
- Bradburn, N. M. (1969). *The structure of psychological well-being*. Chicago, IL: Aldine.
- Brannen, J. (2002). Discourses of adolescence: Young people's independence and autonomy within families. In J. Brannen & M. O'Brien (Eds.), *Children in families: Research and policy* (pp. 114–129). London, England: Falmer Press.
- Caprara, G. V., & Cervone, D. (2000). *Personality: Determinants, dynamics, and potentials*. New York, NY: Cambridge University Press.
- Caprara, G. V., Delle Fratte, A., & Steca, P. (2002). Determinanti personali del benessere nell'adolescenza: Indicazioni e predittori [Psychological determinants of well-being in adolescence: indications and predictors]. *Psicologia Clinica dello Sviluppo, 6*, 203–234.
- Caprara, G. V., & Gerbino, M. (2001). Autoefficacia emotiva: la capacità di regolare l'affettività negativa e di esprimere quella positiva [Affective self-efficacy: The ability

- to manage negative affects and to express positive affects]. In G. V. Caprara (Ed.), *La valutazione dell'autoefficacia* (pp. 35–50). Trento, Italy: Erickson.
- Caprara, G. V., & Steca, P. (2006). The contribution of self-regulatory efficacy beliefs in managing affect and family relationships to positivity and hedonic balance. *Journal of Social and Clinical Psychology, 25*, 603–627.
- Caprara, G. V., Pastorelli, C., Regalia, C., Scabini, E., & Bandura, A. (2005). Impact of adolescents' filial self – Efficacy on quality of family functioning and satisfaction. *Journal of Research on Adolescence, 15*, 71–97.
- Caprara, G. V., Regalia, C., & Scabini, E. (2001). Autoefficacia familiare [Familiar self-efficacy]. In G. V. Caprara (Ed.), *La valutazione dell'autoefficacia* (pp. 63–86). Trento, Italy: Erickson.
- Caprara, G. V., Steca, P., Gerbino, M., Paciello, M., & Vecchio, G. M. (2006). Looking for adolescents' well-being: Self-efficacy beliefs as determinants of positive thinking and happiness. *Epidemiologia e Psichiatria Sociale, 15*, 30–43.
- Caprara, G. V., Scabini, E., Barbaranelli, C., Pastorelli, C., Regalia, C., & Bandura, A. (1998). Impact of adolescents' perceived self-regulatory efficacy on familial communication and antisocial conduct. *European Psychologist, 3*, 125–132.
- Caprara, G. V., Vecchione, M., Barbaranelli, C., & Alessandri, G. (2013). Emotional stability and affective self-regulatory efficacy beliefs: Proofs of integration between trait theory and social cognitive theory. *European Journal of Personality, 27*, 145–154.
- Cavalli, A. (1996). Il prolungamento della giovinezza in Italia: “Non bruciare le tappe” [The prolonged youth in Italy: “Don't forge ahead”]. In A. Cavalli & O. Galland (Eds.), *Senza fretta di crescere* (pp. 31–44). Napoli, Italy: Liguori.
- Cervone, D., & Shoda, Y. (1999). Beyond traits in the study of personality coherence. *Current Directions in Psychological Science, 8*, 27–32.
- Cervone, D., & Williams, S. L. (1992). Social cognitive theory and personality. In G. V. Caprara & G. L. Van Heck (Eds.), *Modern personality psychology: Critical reviews and new directions* (pp. 200–252). New York, NY: Harvester Wheatsheaf.
- Cicognani, E., & Zani, B. (1999/2001). Le Relazioni Familiari in Adolescenza: Modelli, Metodi e Temi di Ricerca [Familiar Relations in Adolescence: Models, Methods and Research Themes]. In R. Ardone (Ed.), *Adolescenti e generazioni adulte* (pp. 19–56). Milano, Italy: Unicopli.
- Cohen, J. (1992). A power primer. *Psychological Bulletin, 112*, 155–159.
- Cohen, J., Cohen, P., West, S. G., & Aiken, L. S. (2013). *Applied multiple regression/correlation analysis for the behavioral sciences*. London, England: Routledge.
- Coleman, P. K., & Karraker, K. H. (1998). Self-efficacy and parenting quality: Findings and future applications. *Developmental review, 18*, 47–85.
- Coleman, P. K., & Karraker, K. H. (2000). Parenting self-efficacy among mothers of school-age children: Conceptualization, measurement, and correlates. *Family Relations, 49*, 13–24.
- Costa, P. T., & McCrae, R. R. (1980). Influence of extraversion and neuroticism on subjective well-being: Happy and unhappy people. *Journal of Personality and Social Psychology, 38*, 668–678.
- De Feyter, T., Caers, R., Vigna, C., & Berings, D. (2012). Unraveling the impact of the Big Five personality traits on academic performance: The moderating and mediating

- effects of self-efficacy and academic motivation. *Learning and Individual Differences*, 22, 439–448.
- DeNeve, K. M., & Cooper, H. (1998). The happy personality: A meta-analysis of 137 personality traits and subjective well-being. *Psychological Bulletin*, 124, 197–229.
- Diener, E., & Lucas, R. E. (1999). Personality and subjective well-being. In D. Kahneman, E. Diener & N. Schwarz (Eds.), *Well-being: The foundations of hedonic psychology* (pp. 213–229). New York, NY: Russell Sage Found.
- Eysenck, H. J. (1991). Dimensions of personality: 16, 5 or 3?—Criteria for a taxonomic paradigm. *Personality and Individual Differences*, 12, 773–790.
- Eysenck, H. J. (1992). Four ways five factors are not basic. *Personality and Individual Differences*, 13, 667–673.
- Eysenck, S. B. G., Eysenck, H. J., & Barrett, P. (1985). A revised version of the psychoticism scale. *Personality and Individual Differences*, 6, 21–29.
- Ferguson, C. J. (2009). An effect size primer: A guide for clinicians and researchers. *Professional Psychology: Research and Practice*, 40, 532–538.
- Gorsuch, R. L. (1983). *Factor analysis* (2nd ed.). Hillsdale, NJ: Erlbaum.
- Hasking, P. A., Coric, S. J., Swannell, S., Martin, G., Thompson, H. K., & Frost, A. D. (2010). Brief report: Emotion regulation and coping as moderators in the relationship between personality and self-injury. *Journal of Adolescence*, 33, 767–773.
- Hu, L. T., & Bentler, P. M. (1999). Cutoff criteria for fit indexes in covariance structure analysis: Conventional criteria versus new alternatives. *Structural Equation Modeling*, 6, 1–55.
- Judge, T. A., Erez, A., Bono, J. E., & Thoresen, C. J. (2002). Are measures of self-esteem, neuroticism, locus of control, and generalized self-efficacy indicators of a common core construct? *Journal of Personality and Social Psychology*, 83, 693–710.
- Kline, P. (1979). *Psychometrics and psychology*. London, England: Academic Press.
- Kline, P. (2000). *The handbook of psychological testing* (2nd ed.). London, England: Routledge.
- Maltby, J., Macaskill, A., & Day, L. (2001). Failure to forgive self and others: A replication and extension of the relationship between forgiveness, personality, social desirability and general health. *Personality and Individual Differences*, 30, 881–885.
- McLaughlin, K., Moutray, M., & Muldoon, O. T. (2008). The role of personality and self-efficacy in the selection and retention of successful nursing students: A longitudinal study. *Journal of Advanced Nursing*, 61, 211–221.
- Mischel, W. (1973). Toward a cognitive social learning reconceptualization of personality. *Psychological Review*, 80, 252–283.
- Mischel, W., & Shoda, Y. (1995). A cognitive-affective system theory of personality: Reconceptualizing situations, dispositions, dynamics, and invariance in personality structure. *Psychological Review*, 102, 246–286.
- Muthén, B., & Muthén, L. (2013). *Mplus 7.1*. Los Angeles, CA: Muthen & Muthen.
- Noller, P. (1995). Parent-adolescent relationships. In M. Fitzpatrick & A. Vangelisti (Eds.), *Explaining family interactions* (pp. 77–111). London, England: Sage.
- O'Brien, R. M. (2007). A caution regarding rules of thumb for variance inflation factors. *Quality & Quantity*, 41, 673–690.
- Park, N. (2004). Positive development: Realizing the potential of youth. *Annals of the American Academy of Political and Social Science*, 591, 40–54.

- Regalia, C., Barbaranelli, C., Pastorelli, C., & Mazzotti, E. (1999). Convinzioni di efficacia filiale e prevenzione del rischio in adolescenza [Filial efficacy beliefs and risk prevention in adolescence]. *Età Evolutiva*, *64*, 60–66.
- Ryan, R. M., & Deci, E. L. (2001). On happiness and human potentials: A review of research on hedonic and eudaimonic well-being. *Annual Review of Psychology*, *52*, 141–166.
- Ryff, C. D. (1989). Happiness is everything, or is it? Explorations on the meaning of psychological well-being. *Journal of Personality and Social Psychology*, *57*, 1069–1081.
- Ruini, C., Ottolini, F., Rafanelli, C., Ryff, C. D., & Fava, G. A. (2003). La validazione italiana delle Psychological Well-Being Scales (PWB) [Italian standardization of Psychological Well-Being Scales (PWB)]. *Rivista di Psichiatria*, *38*, 117–130.
- San Martini, P., Mazotti, E., & Setaro, S. (1996). Factor structure and psychometric features of the Italian version for the EPQ-R. *Personality and Individual Differences*, *21*, 877–882.
- Sanavio, E., & Soresi, S. (1979). L'Eysenck Personality Questionnaire: Prime analisi per un adattamento italiano (The Eysenck Personality Questionnaire: Early analysis for an Italian adaptation). *AP – rivista di Applicazioni Psicologiche*, *1*, 45–64.
- Sanavio, E., Bertolotti, G., Michielin, P., Vidotto, G., & Zotti, A. M. (2006). *Cognitive Behavioural Assessment 2.0*. Firenze, Italy: Giunti O. S.
- Schermelleh-Engel, K., Moosbrugger, H., & Müller, H. (2003). Evaluating the fit of structural equation models: Tests of significance and descriptive goodness-of-fit measures. *Methods of Psychological Research Online*, *8*, 23–74.
- Schutte, P. S., & Ryff, C. D. (1997). Personality and well-being: Reexamining methods and meanings. *Journal of Personality and Social Psychology*, *73*, 549–559.
- Sharp, C., Pane, H., Ha, C., Venta, A., Patel, A. B., Sturek, J., & Fonagy, P. (2011). Theory of mind and emotion regulation difficulties in adolescents with borderline traits. *Journal of the American Academy of Child & Adolescent Psychiatry*, *50*, 563–573.
- Steel, P., Schmidt, J., & Shultz, J. (2008). Refining the relationship between personality and subjective well-being. *Psychological Bulletin*, *134*, 138–161.
- Vernon, P. A., Martin, R. A., Aitken Schermer, J., & Mackie, A. (2008). A behavioral genetic investigation of humor styles and their correlations with the Big-5 personality dimensions. *Personality and Individual Differences*, *44*, 1116–1125.

Author Biographies

Marco Tommasi is a researcher of psychology in the field of intelligence, personality, psychological well-being, and individual differences. In addition, he contributed to the development and validation on psychological tests about the measurement of intelligence and of occupational stress in working places. He is currently teaching at the University of Chieti-Pescara.

Paola Grassi is a PhD student of the University of Chieti-Pescara and she is working about intelligence, personality, psychological well-being, and occupational stress in working places.

Michela Balsamo is a professor of psychology in the field of intelligence, personality, and individual differences. She developed tests for measuring anxiety and depression syndromes. She is teaching applied statistic to psychology at the University of Chieti-Pescara.

Laura Picconi is a researcher of psychology in the field of intelligence, personality, and individual differences. She is also working in the field of psychological tests, especially in personality tests. She is teaching applied statistic to psychology at the University of Chieti-Pescara.

Adrian Furnham is an organizational and applied psychologist, management expert, and professor of psychology at University College London. He is currently adjunct professor at the Norwegian Business School in Oslo. He is also senior fellow at the Civil Service College in Singapore. In addition to his academic roles, he is a consultant on organizations.

Aristide Saggino is a full professor of psychometrics at the University of Chieti-Pescara. He did many researches in the field of intelligence, personality, and individual differences. He developed psychological tests for measuring intelligence, personality, and depression. In addition, he is the president of the AIAMC, the Italian association of cognitive-behavior therapists.