

This file was downloaded from the institutional repository BI Brage -
<http://brage.bibsys.no/bi> (Open Access)

**Any way goes: identifying value constellations for service infusion in
SMEs**

**Christian Kowalkowski
Hanken School of Economics
Linköping University**

**Lars Witell
Karlstad University
Linköping University**

**Anders Gustafsson
BI Norwegian Business School
Karlstad University**

This is the authors' accepted and refereed manuscript to the article published in

***Industrial Marketing Management*, 42(2013)1: 18-30**

DOI: <http://dx.doi.org/10.1016/j.indmarman.2012.11.004>

The publisher, Elsevier, allows the author to retain rights to “post a revised personal version of the text of the final journal article (to reflect changes made in the peer review process) on your personal or institutional website or server for scholarly purposes, incorporating the complete citation and with a link to the Digital Object Identifier (DOI) of the article”. (Publisher’s policy 2011).

Any way goes: Identifying value constellations for service infusion in SMEs

Christian Kowalkowski ^{a,b,*}

Lars Witell ^{c,b,1}

Anders Gustafsson ^{c,d,2}

^a Department of Marketing, CERS – Centre for Relationship Marketing and Service Management, Hanken School of Economics, PO Box 479, FIN-00101 Helsinki, Finland

^b Department of Management and Engineering, Linköping University, SE-581 83 Linköping, Sweden

^c Service Research Center, Karlstad University, SE-651 88 Karlstad, Sweden

^d BI Norwegian School of Management, 0442 Oslo, Norway

* Corresponding author. christian.kowalkowski@hanken.fi, tel: +358 40 3521 457; fax: +358 9 431 33 287

¹ lars.witell@kau.se

² anders.gustafsson@kau.se

Biographical sketches

Christian Kowalkowski is Assistant Professor of Marketing in the Centre for Relationship Marketing and Service Management at Hanken School of Economics (www.hanken.fi), Finland. Dr. Kowalkowski also holds a part-time position as Associate Professor of Industrial Marketing at Linköping University, Sweden. He is currently conducting research on service infusion in manufacturing, dynamics of value propositions, service innovation, and value-creation strategies. He has published articles in journals such as *European Journal of Marketing*, *Industrial Marketing Management*, *Journal of Business Research*, and *Journal of Service Management*.

Lars Witell is Professor of Business Administration in the Service Research Center at Karlstad University, Sweden. Dr. Witell also holds a part-time position as Professor of Business Administration at Linköping University, Sweden. He conducts research on product and service development, customer co-creation and service infusion in manufacturing firms. He has published several articles in scholarly journals such as *Journal of Business Research*, *Journal of Service Research*, and *Journal of Service Management*, as well as in the popular press, such as *The Wall Street Journal*.

Anders Gustafsson is Professor of Business Administration in the Service Research Center (www.ctf.kau.se) at Karlstad University, Sweden. Dr. Gustafsson also holds a part-time position as a Professor at BI Norwegian School of Business, Norway. He is conducting research on customer orientation, customer satisfaction and loyalty, new service development, service infusion in manufacturing, and management of customer relationships. Dr. Gustafsson has published more than 150 academic articles, book chapters, and industry reports. He has published articles in journals such as *Journal of Marketing*, *Journal of Economic Psychology*, *Journal of Business Research*, and *Journal of Service Research*. Dr. Gustafsson is an author of nine books, including *Competing in a Service Economy: How to Create a Competitive Advantage through Service Development and Innovation* (Jossey-Bass, 2003), *Improving Customer Satisfaction, Loyalty and Profit: An Integrated Measurement and Management System* (Jossey-Bass, 2000), and *Conjoint Measurement—Methods and Applications* (Springer, 2007, 4th ed.).

Research highlights

- We investigate how SMEs construct value constellations through relationships with other firms to enable service provision.
- SMEs seldom have the internal resources to build new organizational units or create new specialties.
- We identify nine generic value constellations that can be used to operationalize different service strategies.
- Many SMEs provide services through multiple value constellations that coexist in the same business network.
- This study contests the established view that particular business models are especially suitable for service provision.

Abstract

Manufacturing firms have always delivered services, by supplying spare parts, installing equipment, training employees, or performing maintenance. In competitive markets though, firms seek new ways to differentiate their business, including an increased focus on service, often referred to as service infusion. Of the studies that seek to understand this phenomenon, most focus on large multinational firms; little is known about service infusion in small and medium-sized enterprises (SMEs). This study adopts an explorative approach to investigate how SMEs construct new value constellations that enable value creation through services. The findings, based on in-depth interviews with key informants from 13 SMEs, suggest that there is no predefined transition process for service infusion in SMEs, which seldom have the resources to build new organizational units or create new specialties. Instead, they differentiate themselves through new value constellations within business networks. The heterogeneity of service offerings and business networks means those value constellations take many forms.

Keywords: Service infusion, small- and medium-sized enterprises, value constellation, network, service strategy, service transition

1. Introduction

Firms in various industries are finding that they can no longer succeed just by offering excellent products, traditional after-sales service, and logistics. To differentiate themselves from their competitors, manufacturing firms have begun to extend their range of service offerings and enhance their service orientation (Gebauer, *et al.* 2010a; Martin & Horne 1992). Such changes generally help firms achieve better returns on sales and improve their value (Fang, *et al.* 2008). The resulting importance of services for manufacturing firms has prompted a newly named concept: “service infusion in manufacturing firms”¹ (Gustafsson, *et al.* 2010; Kowalkowski, *et al.* 2012; Nilsson, *et al.* 2001; Ostrom *et al.* 2010).

Most studies of service infusion in manufacturing firms focus on large multinational firms (e.g., Davies, *et al.* 2007; Gebauer & Kowalkowski 2012; Raddats & Easingwood 2010; Ulaga & Reinartz 2011), even though service infusion occurs in all types of supply chains (Löfberg, *et al.* 2010; Matthyssens & Vandenbempt 2008), including those for small and medium-sized enterprises (SMEs)² (Gebauer, *et al.* 2010b). An empirical investigation of European manufacturing firms even concludes that small and medium-sized suppliers of components and subsystems are influenced by service infusion just as much as larger original equipment manufacturers (OEM) are (Lay, *et al.* 2010). With their limited size and resources (Storey & Greene 2010), SMEs may need different tactics if they are to benefit from service infusion in manufacturing firms; we know that they are affected differently than larger firms by an increased focus on service (Gebauer, *et al.* 2010b). Despite a few studies of service infusion in SMEs (Gebauer, *et al.* 2010b; Malleret 2006), no explicit investigations consider how SMEs manage to infuse service into their business.

¹ The empirical phenomenon by which manufacturing firms increase their focus on service also has been referred to as the emergence of “product–service systems” (Stoughton & Votta 2003; Tukker & Tischner 2006) and “servitization” (Baines *et al.* 2009; Neely 2008; Vandermerwe & Rada 1988). We use “service infusion in manufacturing firms” to capture the empirical phenomenon, whose common denominator is the increased importance of service in the offering and organization of manufacturing firms.

² An SME is a firm that employs fewer than 250 employees (European Commission 2003).

In particular, SMEs lack the necessary resources—staff, competences, facilities, and finances—to provide the services that their customers require. Considering their overall reliance on other firms in their network (Gebauer, *et al.* 2010b) and the resources needed to develop and provide new services (Fischer, *et al.* 2010), we posit that SMEs depend heavily on actors in their business network to achieve success with service infusion. Previous research on service infusion has not really examined value creation in the broader network that surrounds a customer–supplier dyad (Matthyssens & Vandenbempt 2008; Ulaga & Eggert 2006; Windahl & Lakemond 2006). Yet firms are embedded in networks of interconnected relationships that form a web of interactions, and this network extends far beyond just two firms (Håkansson, *et al.* 2009). Within the network, firms create value by configuring their portfolio of direct relationships into distinct, specific, and integrated structures (Corsaro, *et al.* 2012; Möller & Rajala 2007), referred to as *value constellations* (Normann & Ramírez 1993; 1994; Ramírez 1999). Such value constellations could serve an important purpose in enabling SMEs to provide services.

This study considers these factors in an analysis of the challenges for an SME when working with service infusion, particularly due to their limited internal resources. Specifically, we investigate how SMEs construct value constellations through relationships with other firms to enable service provision. In-depth analyses of 13 SMEs from a wide variety of manufacturing industries indicate nine generic value constellations for service provision. The results imply there is no general, predefined transition process or value constellation that solves all service infusion challenges for SMEs. Rather, SMEs construct a variety of value constellations to operationalize their service strategies and provide service offerings to customers. Therefore, this study contests the established view that firms undergo specific phases during a service transition trajectory and that particular business models are especially suitable for service provision in a manufacturing context (Gebauer & Kowalkowski 2012; Oliva & Kallenberg 2003; Penttinen & Palmer 2007; Wise & Baumgartner 1999).

2. Theoretical framework

Service infusion is increasingly important for not just large firms but also SMEs. Their limited internal resources and comparatively weaker market positions already force SMEs to engage in value constellations with other actors in the business network; adding the challenge of service infusion likely requires SMEs to turn to their networks and value constellations. We describe six dimensions of service differentiation for value constellations.

2.1 Service infusion and SMEs

Service infusion refers to “an organization-wide embracement of a basic set of relatively enduring organizational policies, practices, and procedures intended to support and reward service-giving behaviors that create and deliver services excellence” (Lytle, *et al.* 1998, p. 459). It reflects the extents to which a firm focuses on service as its core offering and to which customers regard the organization as a service provider (Gebauer 2008; Jacob & Ulaga 2008). Firms with excellent products in a competitive industry can use service as a differentiator, so a common rationale for service infusion involves taking advantage of strategic, financial, and marketing opportunities (Gebauer, *et al.* 2011; Oliva & Kallenberg 2003).

In addition to the research focused on large manufacturing firms (e.g., Gebauer & Kowalkowski 2012; Kowalkowski, *et al.* 2012; Oliva & Kallenberg 2003; Raddats 2011; Raddats & Easingwood 2010; Ulaga & Reinartz 2011), a few studies have included both large firms and SMEs (e.g., Lay, *et al.* 2010; Matthyssens & Vandembemt 2010). The 195 firms analyzed by Gebauer (2008) and Gebauer *et al.* (2010a) were predominantly large and medium-sized firms (250 or more and 50–250 employees, respectively). The focus in these studies is not to draw inferences about different actions based on firm size but rather to study the phenomenon in general.

But several key differences between large OEMs and SMEs must be taken into consideration when analyzing service infusion. Oliva and Kallenberg (2003) argue that manufacturing firms must enter the service market by serving the installed base, but this finding cannot transfer to SMEs, which usually sell through distributors, deliver through installers, and have limited access to their installed base. They tend to supply larger firms themselves (Löfberg, *et al.* 2010), and thus external providers usually are responsible for services related to the products, which further

limits their access. To provide services, SMEs would need to revise their sales channels, motivate distributors to offer services, and arrange paybacks from customers to distributors and then from distributors to the SME (Gebauer, *et al.* 2010b).

Another obstacle is the need for a separate service organization with specific profit-and-loss responsibilities (Gebauer & Kowalkowski 2012; Oliva & Kallenberg 2003). It can be difficult to combine a service organization with a traditionally product-focused organization, which often will maintain its existing priorities. Yet SMEs probably lack the critical mass that a service business requires to be profitable on its own (Fundin, *et al.* 2012). In addition, a separate service organization adds complexity to an SME's structure, which creates higher coordination costs and limits flexibility (Kowalkowski, *et al.* 2011a). Finally, SMEs have fewer internal resources in terms of financing and skilled personnel compared with large firms (Storey & Greene 2010), so they likely struggle with initiatives to set up separate service organizations.

If SMEs also lack the resources to invest in new equipment, their offering may be more labor-intensive or depend on another actor in the network with the right resources (Ulaga, *et al.* 2002). Therefore, the success of SMEs with service infusion should be more dependent on other actors in their business network than is the case with large organizations. There is, however, a need to examine value creation in the broader network surrounding customer-supplier dyads (Matthyssens & Vandenbempt 2008; Ulaga & Eggert 2006; Windahl & Lakemond 2006).

2.2 Networks and value constellations

In business markets, suppliers and customers often establish and develop long-term business relationships (Ford & Redwood 2005; Grönroos 2006; Hallén, *et al.* 1991). Scholars in multiple research streams recognize the importance of emphasizing long-term business relationships, interactions, and networks through a focus on the firm's customers, suppliers, and other central actors in the network (Coviello, *et al.* 2002; Ford 2011; Gummesson 2006; Håkansson & Snehota 1995; Lindgreen & Wynstra 2005; Lusch, *et al.* 2010). Firms create networks in the context of interconnected business relationships (Gadde, *et al.* 2003), which represent metaphorical and analytical tools to describe network nodes, or linkages between firms, located in time and space

(Håkansson & Ford 2002). Firms are held together by various competences, relationships, and information (Lusch, *et al.* 2010), and each firm's competences include those it can exploit from other actors in its network (Araujo, *et al.* 2003). Håkansson and Snehota (2006) thus argue that a firm's most valuable resource is its relationships with other actors in the network.

Relationships in business networks with distinct structures reflect intentionally created constellations of actors. These actors pursue repeated, enduring exchange relations with one another and deliberately work together to mobilize value creation (Achrol 1997; Dyer & Nobeoka 2000; Lorenzoni & Lipparini 1999; Podolni & Page 1998). We conceptualize these structures as value constellations (Normann & Ramírez 1993) and adopt an actor-defined perspective, such that a focal actor strives to configure adjacent business relationships through networking activities (Corsaro, *et al.* 2012; Hinterhuber 2002). In value constellations, value creation is an outcome of interactions among actors (Ramírez 1999), and competitive advantage exists at a constellation, rather than firm, level (Gomes-Casseres 1994; Möller & Svahn 2006; Normann & Ramírez 1994). By conceiving of value creation in the context of systemic business networks, firms can find opportunities to improve their effectiveness and adaptability (Lusch, *et al.* 2010). Kindström (2010) argues that it is particularly crucial to cultivate relationships with other actors in the business network early in the process of moving toward service provision, when in-house infrastructures may be weak.

Through several different routes, SMEs can engage their business network successfully and construct value constellations to deal with the importance of the service to their offering. To put service infusion into practice, value constellations must contain capabilities for service infusion (Ramírez & Wallin 2000) and reflect both a market orientation (Kowalkowski, *et al.* 2012) and a service strategy (Gebauer 2008; Gebauer, *et al.* 2010a). In addition, the value constellations include different modes of coordination (Lorange & Roos 1992), types of integration (Davies 2004; Galbraith 2002), and interfirm adaptations (Hallén, *et al.* 1991). We therefore present six value constellation dimensions that serve as the basis for our case analysis in our empirical investigation.

2.2.1 Capabilities

Service infusion creates a need to develop new resources or *capabilities*, defined as “repeatable patterns of action in the use of assets to create, produce, and deliver offerings” (Ramírez & Wallin 2000), to manage a service-oriented business. New and necessary operational capabilities might include maintaining, operating, or renovating a product throughout its operational life cycle (Brady, *et al.* 2005). Yet alone such operational capabilities cannot achieve the expected level of service profits and revenues; other capabilities must exist to form new value constellations within the business network (Fischer, *et al.* 2010). A reconfiguration of roles and relationships among different actors can enable value creation in new forms and by new actors, as well as generate improved fit between capabilities and customers (Normann & Ramírez 1993). It is not enough to have operational “core-value production” capabilities (e.g., production, delivery, process improvement). To varying degrees, firms need what Möller and Törrönen (2003) call “relational value production” and “future-oriented value production” capabilities—innovation, relational, and networking capabilities. Firms that infuse services to become systems integrators also must be able to design and integrate systems with internally and externally developed product and service elements (Davies, *et al.* 2007). Relational and networking capabilities are needed too, because the development of new services often takes place through mutual investments and adaptations among the supplier, the customer, and other actors in the business network (Möller & Törrönen 2003).

2.2.2 Market orientation

Service infusion and relationship dynamics entail a type of *market orientation*. Jaworski *et al.* (2000) distinguish market-driven from market-driving orientation: The former indicates a *reactive* response to network changes, whereas the latter is a *proactive* market strategy that changes the existing network. Adapting to conditions set by customers, competitors, and other actors in the business network is reactive, but proactivity entails “taking initiative in improving current circumstances or creating new ones ... challenging the status quo rather than passively adapting to present conditions” (Crant 2000, p. 436).

In a study of product development initiatives, Narver *et al.* (2004) find that a reactive, market-driven orientation cannot create or sustain success. However, several studies of service infusion in manufacturing indicate that firms tend to act reactively when they increase the service share of their business (e.g., Gebauer, *et al.* 2011; Kowalkowski, *et al.* 2012; Löfberg, *et al.* 2010; Matthyssens & Vandenbempt 2010). The firms analyzed in these studies are large, multinational manufacturers though, so their reactionary stance might result from their relatively profitable core (product) business and difficulty of transforming existing capabilities and developing a new resource base—what Lieberman and Montgomery (1998) refer to as “incumbent inertia.” For SMEs, a reactive, market-driven orientation likely reflects their need to adapt continuously to market turbulence and new customer demand. In the automotive industry for example, many SMEs are under pressure to infuse services to deliver more to key customers (Löfberg, *et al.* 2010). Thus, there may be limited business rationales and opportunities for a proactive orientation; to survive, SMEs must adapt to the conditions set by their OEM customers.

2.2.3 Service strategies

In contrast with a perspective that suggests service infusion is a generic strategy (e.g., Kotler 1994; Levitt 1980), Mathieu (2001, p. 452) suggests the presence of “a great heterogeneity among manufacturing firms regarding their service approaches.” Some companies limit their service offerings to traditional product-related services, such as after-sales services, but others try to market unique service offerings. Gebauer (2008) argues that firms’ service strategies differ with the external environment in which they operate. Furthermore, each service strategy requires a different organizational design, which implies the need for a specific configuration and fit between the strategy and the organization. Gebauer *et al.* (2010a) outline five generic service strategies:

- *Customer service.* Add customer services during the sales phase in an existing customer activity chain, focusing on services related to the sale of the products, such as information or billing services. Service offerings aim to increase customer satisfaction and strengthen the credibility of the manufacturing firm.

- *After-sales service provider.* In highly competitive markets with very price-sensitive customers, suppliers offer basic services for the installed base, such as repair, maintenance, and overhaul.
- *Customer support service provider.* With low competitive intensity, concentrating on optimizing customer processes, suppliers offer maintenance services, including preventive maintenance agreements, refurbishment, and process optimization.
- *Outsourcing partner.* When the market is highly competitive and customer interest in reducing the initial investment and operating risks is strong, a supplier can offer operational services and take responsibility for the customer's operating processes.
- *Development partner.* With low competitive intensity, collaborative innovations can arise from a supplier that offers R&D-oriented services but also pays intermediate attention to after-sales and process-oriented services.

Löfberg *et al.*'s (2010) empirical investigation of the automotive industry reveals that SMEs occupy different positions in the business network than OEMs. The SMEs are often suppliers of components and subsystems; they do not have a final product of their own. They find it difficult to move downstream because of the potential for competition with their actual customers, distributors, and installers. Whereas OEMs adopt after-sales service strategies, suppliers in the supply chain tend to be development partners or pursue a customer service strategy. The main reasons for the difference relate to differences in customer demand and the relevant products. Investigating the different service strategies and roles that an SME can adopt in the business network is of interest, to expand research on business networks that has focused on large manufacturing firms (e.g., Ford 2002; Håkansson & Snehota 1995).

2.2.4 Modes of coordination

Overall, long-term business relationships become more critical when services are infused (Oliva & Kallenberg 2003; Penttinen & Palmer 2007), but the degree of commitment and coordination between actors can produce different *modes of coordinating*. The coordination continuum ranges from non-existent (spot market) verbal agreements to formally specified contracts. They can be short or long term, single-level or multilevel. Coordination can take the form of a relationship-based alliance (e.g., key account liaison, strategic partnerships), an equity-based alliance (e.g., joint ventures, equity strategic alliances), or company integration through mergers or acquisitions (Lorange & Roos 1992; Peterson, *et al.* 2001).

2.2.5 Types of integration

Another distinction refers to *vertical* or *horizontal integration* (Chandler 1990; Galbraith 2002). Vertical integration refers to a combination of several phases in the flow of activities that moves raw material to end-user services. It encompasses forward integration, which implies movement downstream, and backwards integration, which is a movement upstream (Davies 2004; Porter 1998). Horizontal integration instead refers to the combination of several activities in the same phase of manufacturing or service processes (Chandler 1990). In practice, vertical integration often involves collaborations with firms in other parts of the supply chain; horizontal integration entails collaboration with firms in the same level of the supply chain. Therefore, the firm's value constellations vary depending on its type of integration.

Through new value constellations, a manufacturing firm can offer additional services that are not available in-house and benefit from local market access and increased responsiveness. Firms should scan the business network for opportunities to enhance their offerings, select and cooperate with new service partners to enable their service provision, and establish a coordinating position within the network (Kindström 2010). However, even as linkages with other actors create possibilities for value creation, they constrain potential opportunities through their inherent dynamism and inflexibility in the network (Håkansson & Ford 2002). For example, firms that infuse services rely heavily on downstream actors' inclination to collaborate (Matthyssens & Vandembemt 2008). Because SMEs have weaker positions in the business network than OEMs

(Storey & Greene 2010) and already rely on other actors in the network for service provision (Gebauer, *et al.* 2010b), it seems necessary for them to establish new value constellations, either vertical or horizontal, to leverage their business potential. In this process, SMEs likely require the assistance of other actors in the network.

2.2.6 *Interfirm adaptation*

Regardless of the size of the firm, the success of new value constellations demands *interfirm adaptation* (Tuli, *et al.* 2007), which implies that one or both of the actors in the relationship “make adaptations to bring about initial fit between their needs and capabilities, but adaptation also may be necessary in an ongoing relationship as the exchanging parties are exposed to changing business conditions” (Hallén, *et al.* 1991, p. 30). Hallén *et al.* (1991) describe two forms of adaptation: *unilateral* and *reciprocal*. A firm incurs costs when it makes unilateral adaptations, but those adaptations should pay for themselves by contributing to stronger business relationships. Although it can be difficult to transfer reciprocal adaptation to other uses, mutual investments also can create stronger relationships, which enable business expansion and an opportunity to secure business-critical resources. When manufacturing firms infuse services, they require a reciprocal adaptation strategy that includes integration, open dialogue, interaction in development, and co-marketing initiatives (Matthyssens & Vandenbempt 2008).

3. Methodology

This study aims to achieve a comprehensive understanding of how SMEs deal with service infusion in the manufacturing industry. A particular goal is to identify one or several value constellations that SMEs use for service provision. Therefore, we employed a multiple case study approach, which offers an effective way to gain new knowledge about a specific phenomenon (Eisenhardt 1989) and make a conceptual contribution (Siggelkow 2007). The emphasis on understanding that is inherent to case study research implies a direct emphasis on theory building (Meredith 1998). Meredith (1998, pp. 442-443) defines a case study as a method that “typically uses multiple methods and tools for data collection from a number of entities by a direct

observer(s) in a single natural setting that considers temporal and contextual aspects of the contemporary phenomenon under study, but without experimental controls or manipulations.” Abductive case study research is distinctive, in that researchers go back and forth between theoretical insights and empirical observations (Dubois & Gibbert 2010). Following Järvensivu and Törnroos (2010), we use abduction, with a substantial degree of induction in early phases and more deduction in the later phases when we analyze the identified value constellations according to the dimensions from our theoretical framework.

3.1 Case selection

This multiple case study concentrated on SMEs in several industries, such as pulp and paper, automotive, and machinery, in which several firms act as suppliers to large, multinational manufacturers. Such firms rely heavily on exports, but increasing product commoditization and low-cost competition has led manufacturing firms to turn to service provision too. Previous research provides empirical evidence that SMEs are heavily influenced by service infusion (Lay, *et al.* 2010) but does not indicate the form or extent of this influence, nor whether it differs from the influence on large manufacturers. To address this gap, we focused on SMEs with fewer than 250 employees and that provide services in addition to their core products.

With the assistance of an industry expert, we identified potential SMEs in a range of industries. Thirteen SMEs that represented (1) different industries, (2) different positions in the supply chain, and (3) various sizes, agreed in an initial telephone contact to participate in a study of value constellations for service provision. The descriptive statistics in Table 1 provide an overview of the participating firms (the names have been changed to protect confidentiality). Most of these SMEs are suppliers to large OEMs, but a few cases represent positions closer to the end customer in the supply chain, such as Wrecker Ltd., which rebuilds an OEM’s products.

- Insert Table 1 about here -

3.2 Data collection

We collected data from the SMEs during site visits and interviews with managers. All firms in the sample were Swedish SMEs with multinational customers. We conducted between one and three site visits to each firm, as well as one to six interviews with employees. In 20 total site visits, we conducted interviews with 25 CEOs and managers. The relatively few interviews for each firm was acceptable because each firm involved only a few key individuals in strategic service provision. Moreover, there was no common, specific management role responsible for services in SMEs across the 13 firms; they included the CEO, marketing manager, service manager, and production manager. Because the firms were SMEs, the respondents all should have a thorough understanding of service provision in their firm though.

The interviews followed a semi-structured interview protocol, designed to gain a better understanding of how firms construct value constellations for service provision. Each interview lasted up to 120 minutes and was recorded and transcribed, resulting in a total of 400 pages of text. As recommended by Eisenhardt (1989), an independent researcher performed the data collection, and a research team carried out the data analysis to achieve complementary insights and enhanced confidence in the findings. Secondary sources were also consulted, including mission and strategy documents, market communication of service offerings, web page information, and industry statistics. The combination of internal documents, publicly available material, and data gathered in interviews offers data source triangulation (Gibbert, *et al.* 2008; Yin 2003), which helps ensure the reliability and construct validity of the findings.

3.3 Data analysis and interpretation

The data analysis was based on detailed write-ups about each case firm. An independent researcher developed these write-ups, which the research team then used to identify value constellations for each service. The research team also revisited the original data to find greater detail about each value constellation and thereby describe, understand, and analyze them in detail. The firm provided the unit of analysis in this case, and the analysis of each value constellation took the perspective of the SME. For the data coding, we summarized the data by pulling together themes and identifying patterns in accordance with a coding scheme. We

conducted additional interviews for several value constellations for which we required more detail to understand their logic.

In turn, we identified 19 value constellations for service provision. Cross-case analysis helped us distill the identified value constellations into nine generic value constellations that SMEs use for service provision. To ensure internal validity, each value constellation was categorized on the basis of the six theoretically triangulated dimensions for service differentiation: capabilities (Ramírez & Wallin 2000), market orientation (Kowalkowski, *et al.* 2012), service strategy (Gebauer 2008; Gebauer, *et al.* 2010a), modes of coordination (Lorange & Roos 1992), integration (Davies 2004; Galbraith 2002), and interfirm adaptation (Hallén, *et al.* 1991).

We also confirmed the reliability of the research by making the research methodology transparent and repeatable through our use of a semi-structured interview guide, an independent researcher to perform the detailed case descriptions, and collation of all the transcripts and case study documents collected during the study. These procedures make it possible to repeat the study with similar results (Yin 2003). In addition, data triangulation and multiple interviewers (where possible) improved construct reliability. The theoretical framework of six dimensions for service differentiation guided the cross-case analysis, together with a theoretical sampling procedure to improve internal and external validity.

4. Adopted value constellations for service provision

Customers of all firms in our study expected more extensive offerings from their suppliers, and as a consequence, firms needed to infuse services into their core products. In many cases, this development went hand-in-hand with the customers' desire to reduce their supplier base and suppliers' wishes to build stronger customer relationships. The SMEs in our study acted, either proactively or reactively, and responded to changes in the business network by adopting new value constellations for service provision.

All of the firms delivered basic, product-related services directly to their customers, without the involvement of distributors or other external partners (cf. Gebauer, *et al.* 2010b). These services are restricted to those that support the sale and installation of products or the provision of spare parts. In addition, manufacturing firms have responded to the increased complexity of their customers' needs by forming relationships with other firms to meet increased demands for services (Gebauer, *et al.* 2011; Kowalkowski, *et al.* 2011a). The case companies participated in one or more of the nine identified value constellations, in addition to basic product-related services. We illustrate the value constellations in Figure 1 and describe them in more detail in Table 2.

- Insert Figure 1 about here -

- Insert Table 2 about here -

4.1 Systems integration

The first value constellation, systems integration, resembles the general service infusion undertaken by many large manufacturing firms (Davies, *et al.* 2007). The SME is the customer's sole supplier and acts as an integrator, with the aim of reducing the supplier base. In this value constellation, it becomes particularly necessary to manage relationships with subcontractors and customers. Relationships between an SME and its subcontractors are often informal, so only the SME adapts to the provision of services; the subcontractors continue with business as usual. All five service strategy configurations described by Gebauer *et al.* (2010a) are possible. Compared with the large, high-technology enterprises and systems in previous studies (e.g., Hobday, *et al.* 2005; Prencipe, *et al.* 2003; Windahl & Lakemond 2010), our findings reveal a minimal system scope and low level of technological complexity. Six SMEs reactively took a role as systems integrators, such as by designing, assembling, and integrating physical components and embedded services, which enabled them to offer new combinations of products and services through extensive systems and solutions. Firms such as Hydro Power Ltd., Inertia Ltd., and Tankhouse Technology Ltd. engage in minimal in-house manufacturing activities and instead have developed a well-functioning network of subcontractors. At Alu Ltd., the value constellation

also is project specific, in that large customers advocate which other actors to involve in systems development.

4.2 Customer-to-customer intermediary

The C-to-C intermediary value constellation involves unilateral adaptation and formal relationships with exchange parties. This value constellation is consistent with an after-sales service strategy in which the firm performs downstream vertical integration. Wrecker Ltd. rebuilds trucks into tow trucks, using a customized process for each truck. When the firm moved into services, it proactively created an online marketplace for its customers to sell and buy used tow trucks. Wrecker Ltd. also collaborates with buyers and sellers, though without becoming actively involved unless a customer asks it to participate. Sellers pay a small fee to advertise in the online marketplace, but this service is not a major profit generator for the firm. Rather, the marketplace's key purpose is to increase customer loyalty by offering a complementary service and create contacts with potential new customers, such that Wrecker Ltd. is the first place customers search when they need a new truck.

4.3 Competence co-location

This value constellation involves reciprocal adaptation and multilevel, long-term relationships in which a business outpost is established in or near the customers' location. Competence co-location relates to the service strategy in which the SME becomes an outsourcing partner through downstream vertical integration. For an SME, it requires taking over both machinery and personnel from the customer to build the necessary competence and capacity. The key to success is an ability to coordinate work across several locations with limited resources; the key competitive advantage is proximity to customers. Thus Mill Service Ltd. took over its customer's maintenance organization, which involved only low capacity utilization and was not economically feasible for the customer to keep in-house. Mill Service Ltd. could achieve higher service productivity in turn by offering such services to external customers.

4.4 Specialist externality

Specialist externality involves reciprocal adaptation and close cooperation between the SME and specialist with unique competences to augment the offering. The competence of the external partner enables the SME to integrate horizontally and adopt a development partner service strategy governed by formal agreements. Since the 1960s, Acoustica Ltd. has worked as a subsupplier to the automotive industry, for which it provides basic acoustic calculation services for free, with payment coming from resulting product sales. By proactively bringing external partners with expertise knowledge and better equipment into the business network and extending its service provision to include advanced calculation services and technical reports, Acoustica Ltd. began to charge separately for products and services, as well as export services to Asia. The key was to make clear to customers that its development services require new capabilities, for which it must be able to charge.

4.5 Shared service platform

The shared service platform value constellation builds on reciprocal adaptation and formal agreements. It involves horizontal integration and collaboration in establishing prerequisites for services (Edvardsson 1996), but the partners perform service provision individually. Establishing prerequisites for service might take place at different stages of the supply chain and for all the service strategies except customer service, depending on what the cooperation involves. Dredge&Dig Ltd. initiated a cooperation with a leading raw material supply firm for R&D to develop new products with improved durability. The proactive cooperation has resulted in three patents and a service platform that enables the firm to offer more advanced calculation services.

4.6 Dual customer contact partnership

The dual customer contact partnership value constellation involves reciprocal adaptation and coordination, ranging from informal agreements to multilevel, formal agreements. It is consistent with an after-sales or customer support service strategy, and integration can be either horizontal or vertical. To deliver large projects and gain access to new customers, Dredge&Dig Ltd. initiated a manufacturing and sales partnership with an international partner that sells harbor-dredging systems. Although both firms interact with customers, the partner makes the first sales contact, whereas the SME maintains the customer relationship throughout the lifecycle of the

installed base, which provides opportunities for service selling. Because the partner is product-centered and owns the sales interface, Dredge&Dig Ltd. adopted an after-sales service strategy, offering inspection, diagnosis, and repair services. The other SME with this value constellation is Surface Ltd., which initiated informal collaborations with other industrial painting firms, enabling it to offer assembly, packaging, and delivery services for its partners' products too.

4.7 Horizontal collaboration

Three of the SMEs cooperate with other suppliers of complementary products in a value constellation called horizontal collaboration. Thus, these SMEs are more appealing as potential partners for customers that want to reduce the number of suppliers. In this value constellation, partners tend to take the same horizontal position in the business network and their cooperation is rather informal, with limited reciprocal adaptation. It is consistent with a customer service, after-sales service, or development partner strategy. For example, Valve Ltd. is part of a horizontal collaboration in which customers asked the firm to provide a wider range of spare parts and installation services. By widening the range of its offering through close, informal relationships, the firm attracted orders for maintenance plans and training services that it would not have received otherwise. In contrast, Dredge&Dig Ltd. actively sought additional partners. By extending the range of its offering through horizontal collaborations, the firm has not only sold more products and services but also been able to charge for its logistics services, which it previously provided for free.

4.8 Integration co-location

With integration co-location, several SMEs co-locate their businesses to share resources and adapt to systems selling. Partners can share human resources with specialized competences, and even service and sales personnel, to make better use of those resources. The nature of the relationships in this value constellation range from informal cooperation to mergers, and their integration can be both horizontal and vertical. Although all five service strategy configurations should be possible, for Pipe Ltd., only an after-sales strategy was viable. It manufactures quick-coupling pipes and cooperates with two other SMEs located in the same building. Two partners own the customer interface and perform sales of the goods and services; the third is a pure

manufacturer that produces spare parts and customizes products. The value constellation thus provides Pipe Ltd. with knowledge, skills, and additional capacity to provide installation and other after-sales services.

4.9 Competence acquisition

Finally, in competence acquisition, an SME chooses to internalize another SME to access its specific manufacturing, services, or marketing competences. Unlike the other value constellations, the nature of the relationship is formal, and more adaptation is needed to make the acquisition profitable. Integration can be horizontal or vertical, and customer support service, outsourcing partner, and development partner strategies are consistent with this value constellation. In the case of Turnkey Ltd., acquiring an engineering workshop provided process improvement capabilities that enabled it to offer calculation services and better estimate the cost of higher quality service offerings. In addition, the manufacturing capability provided a vertical extension of the firm in the supply chain.

5. Discussion

5.1 Constructions of value constellations

Research on service infusion in manufacturing firms generally focuses on larger firms with sufficient internal resources to add services to the core product. These resources may be used to buy a new firm, form a completely new business unit, or build the capacity for service provision, even if that means running the business at a loss for a certain period. Although some SMEs in our case study bought firms to become service providers, in general they lack the necessary resources, so they must construct other value constellations to become service providers. There is great heterogeneity among SMEs in terms of what they produce, what their customers produce, and the type of business network to which they belong, which results in the wide variety of possible value constellations in Figure 1. To some degree, this range of identified value constellations implies that existing literature describing the transition from manufacturing firms to service providers does not apply to SMEs (e.g., Gebauer & Kowalkowski 2012; Oliva &

Kallenberg 2003; Neu & Brown 2005; Penttinen & Palmer 2007). Some of the identified value constellations already have been adopted by large manufacturers (e.g., systems integration, integration co-location, competence acquisition), but it seems that SMEs tailor the value constellation to a greater extent, to fit with their offering and what their network of partners and, in some cases, customers can support. Thus, SMEs adopt value constellations tailored to the needs of their customers, which strengthens their customer and partner relationships and secures necessary capabilities for them. This transition appears preferable to trying to follow some prescribed process that a larger firm would follow. Larger firms, with thousands of employees and various business units, face a different type of challenge (e.g., Gebauer & Kowalkowski 2012; Kowalkowski, *et al.* 2012).

The initiative to form new value constellations comes from a search for new capabilities for service provision, including operational capabilities such as production, delivery, and service process improvement. However, as Fischer, *et al.* (2010) and Normann and Ramírez (1993) indicate, these capabilities are not enough to form successful value constellations. The success of value constellations relies largely on the ability to handle business relationships, both with customers and within the business network (i.e., relationship and network capabilities). These capabilities are vital for all SMEs, regardless of the type of value constellation, to play a coordinating role. Developing and strengthening existing customer relationships, as well as building new ones, often requires deeper collaboration with vertical or horizontal partners.

But SMEs organize not just for increased service provision through different value constellations but also due to their industry and type of service. For example, to become a system integrator, Turnkey Ltd. integrated backward and acquired three small workshops with manufacturing and engineering capabilities, to move these capabilities in-house and control the entire process from design to assembly. Thus, the SME combined two value constellations (systems integration and competence acquisition) to operationalize its service strategy. Dredge&Dig Ltd. is active in three value constellations: shared service platform, dual customer contact partnership, and horizontal collaboration. In this case, the firm constructed a specific value constellation for each type of service it provides.

We argue that these different value constellations arise because of a functional link between the demands placed on organizations by their contingencies and the organizations' ability to meet those demands. Furthermore, because an organization must always satisfy multiple functions (Miller 1996), there are multiple, coexisting ways a value constellation can provide services. To benefit from service infusion, SMEs must establish value constellations to bring together the right capabilities, and different value constellations may be required to provide a wide range of services and respond to idiosyncratic customer demands. Managing service provision thus demands a capability not just to find the "best" value constellation but rather, as the Dredge&Dig Ltd., Hydro Power Ltd., Inertia Ltd., Mill Service Ltd., and Turnkey Ltd. cases illustrate, to develop parallel value constellations that are internally coherent and heterogeneous enough to cover the range of services provided.

5.2 SMEs act proactively toward service infusion

Adaption is key to understanding how SMEs take advantage of different value constellations. Most firms in the study use a reciprocal adaptation strategy, which implies integration, open dialogue, interaction in development, co-marketing initiatives, and knowledge sharing. It also may explain the lack of formal agreements for certain value constellations. Systems integrators use verbal agreements with several subcontractors and the absence of long-term agreements increases flexibility. Despite its use of informal agreements, Tankhouse Technology Ltd. has never had a delayed customer delivery.

The search for a partner often takes place within an existing business network and ongoing business relationships. In rare cases, SMEs search beyond these boundaries though. Firms in the dual customer contact partnership and C-to-C intermediary constellations must gain new market channels and direct access to customers. In contrast, firms use the specialist externality and shared service platform value constellations to acquire an ability to create prerequisites for services through innovation capabilities. Considering SMEs' limited resources, the high costs of internalizing specialized knowledge and skills, and the pace of technological change in many of the industries, collaboration with external experts offers the only feasible option for these firms.

External experts might be specialized consultants or R&D-intensive firms, which could be either other SMEs or larger firms. However, a few SMEs have acquired other SMEs (competence acquisition), such as small firms whose owner is retiring and wants to sell the firm. These owners might be more interested in the firm's legacy, not the profit on the sale. As for large firms, there may be a business rationale for coordinating through acquisition rather than interfirm collaboration (Trautwein 1990), though SMEs have fewer acquisition opportunities with their minimal financial resources.

Unlike previous studies (e.g., Löfberg, *et al.* 2010), we find that most SMEs behave proactively to achieve service infusion. Löfberg *et al.* (2010) focused on the supply chain in the automotive industry, whereas our study investigates SMEs in a range of industries. In addition, Fang *et al.* (2008) and Gebauer *et al.* (2011) show that market turbulence drives service infusion. Even if SMEs have little choice but to start working with services, they can face the situation and act proactively to form value constellations that increase service breadth and complexity. The proactive behavior required to form most of the value constellations indicates that many SMEs are more proactive and nimble than are large industry incumbents (Kowalkowski, *et al.* 2012). They simply must be to survive. Although it is more challenging for SMEs to orchestrate service provision and value creation activities, they serve an active, market-driving orchestration purpose in value constellations. Many SMEs demonstrate their ability to design, organize, and manage the creation and reconfiguration of value constellations to reach their objectives (Bortoluzzi, *et al.* 2008). This network capability (Möller & Törrönen 2003) relates to the ability to orchestrate the value constellation of actors involved in the various stages of service provision.

Our study also contradicts previous service infusion studies regarding customer relationships. Gebauer, *et al.* (2010b) study service infusion in capital goods manufacturing SMEs, and most of the firms sell to distributors (i.e., indirect customer relationships). In addition, SMEs have limited access to their installed base in the automotive industry (Löfberg, *et al.* 2010). However, the SMEs in this study had direct customer relationships both before and after their service infusion initiatives (cf. Wrecker Ltd.). As a possible explanation, many of the SMEs, which operate in very different industries, produce customized offerings or small tailored batches of low volume.

We posit that such operations facilitate direct customer relationships, and a limited installed base is less cumbersome to service internally, whereas servicing a large installed base induces significant fixed costs that aggravate the situation for firms with limited resources (Kowalkowski, *et al.* 2011a). They already have direct relationships with customers; in many cases, service infusion provides a tactic to retain and strengthen relationships.

5.3 Service strategies and revenue models

The various value constellations fit well with the alternative service strategies suggested by Gebauer *et al.* (2010a). Löfberg *et al.* (2010) find that suppliers in the automotive industry adopt either a customer service or development partner strategy, but we identify all five service strategies among the SMEs in our study. Thus, an SME can set up independent service provision through a customer service or development partner strategy, but a value constellation is needed to adopt more demanding service strategies. Gebauer (2008) suggests that firms use different service strategies depending on the external environment in which they operate. They simply adopt a service strategy and form value constellations based on their networks and competition—which might explain the heterogeneity we find. Gebauer *et al.* (2010a) also state that different organizational designs are required for each service strategy, implying a demand for specific configurational fit between the strategy and the organization to succeed with service differentiation. However, the SMEs do not have the resources they need to build the necessary organizational units. Instead, they use the resources available within their business network and relationships to form new value constellations. These resources differ extensively.

Another difference is that SMEs may not have sufficient leverage and customer relationships to capitalize on service infusion. The CEOs and managers of most SMEs pointed to the difficulty of charging for services, particularly because their revenue models are based on product unit sales, and large customers expect to receive services for free. These difficulties are supported by prior research, which suggest that firms may find it hard to determine the cost of services and that many firms lack consistent pricing strategies (Anderson & Narus 1995; Mathieu 2001). Over the years, SMEs have developed many services on an ad hoc basis, often in response to specific customer demands. The customers of Alu Ltd., Surface Ltd., and other firms, particularly large,

key customers, expect such services to be included in the price of the product. However, as the number of offered services has grown, so has the cost of providing them. The introduction of new value constellations makes it easier for SMEs to charge for services, because many customers understand and accept that they have to pay for new capabilities in the business relationship.

Contract Mfg. Ltd. has made several attempts to change its service strategy by introducing new codevelopment and testing services. Some introductions have been problematic though, because customers were not willing to pay for the new services. Thus the firm maintained its strategy of offering primarily after-sales services, instead of becoming a development partner. Acoustica Ltd. experienced a similar problem, but as a result of its close collaboration with an external specialist, the firm successfully changed the perception that many customers had, and it became the most valuable part of the firm's offering. Acoustica Ltd. then could market and charge separately for its noise-reducing solutions. Unlike the other SMEs, Valve Ltd. chose to limit its service portfolio to services related to the sale of the product; in other words, it adopted a customer service strategy (Gebauer, *et al.* 2010a). The firm has a traditional revenue model based on product sales and does not charge for services; instead, the cost of service provision is included in the product price.

Overall, the SMEs in our study charge for services to varying extents, and the numbers and types of services depend largely on the firm's service strategy. As in the case of Contract Mfg. Ltd., the customer and network characteristics also may inhibit certain service strategies, which means that firms may be unable to shift service strategy configurations, at least in the short term. The product orientation of customers and other actors in the immediate network, as well as their unwillingness to make adaptations to facilitate the SMEs' service strategies, have impeded many initiatives.

6. Conclusions

6.1 Theoretical implications

Over time, the business of manufacturing firms has evolved from an emphasis on the sale of products and gaining market share toward developing business relationships with customers, such that offerings based on both products and services drive growth and revenues. To understand how service infusion influences SMEs and how SMEs handle this multifaceted evolution, it is necessary to understand how they can adopt different value constellations to find the resources needed to put a service strategy into practice.

This study contributes to existing research on service infusion in manufacturing firms by changing the perspective and examining how SMEs, often as sub-suppliers, deal with service provision. Service infusion differs between SMEs and large multinationals, challenging the findings of previous studies that suggest predefined transition lines for service infusion (e.g., Matthyssens & Vandenbempt 2008; Oliva & Kallenberg 2003; Penttinen & Palmer 2007; Raddats & Easingwood 2010). These frameworks often propose multiple stages and list certain activities a firm must perform to reach the next stage and ultimately become a service provider. Our study suggests that “any way goes” for SMEs; they can succeed with service provision through different value constellations. We have identified nine generic value constellations that can be used to operationalize different service strategies.

Despite their limited size, many SMEs provide services through multiple value constellations that coexist in the same network. Regardless of the potential difficulties involved in coordinating multiple, very different value constellations (Corsaro, *et al.* 2012), SMEs proactively (or reactively) form new value constellations to achieve their service strategies. Specific constellations may be needed to develop and provide particular services, which means that firms with a wide range of services, such as basic after-sales services, process optimization, systems integration, and operational services, may need to form and manage more than one value constellation. Managing service provision is not achieved by a framework that discovers the “best” value constellation but instead by developing parallel value constellations that are internally coherent to cover heterogeneity in the range of services. Proactive SMEs especially take different approaches in their attempt to increase value-in-use for customers and thus service

revenues. Unlike large manufacturing firms that are internally organized in spatially dispersed local and central functions and distinct business units though (Gebauer & Kowalkowski 2012; Kowalkowski, *et al.* 2011b), SMEs generally have limited internal resources and limited ability to arrange intrafirm value constellations that can cover a wide range of service offerings. Thus, multiple value constellations may be a logical consequence of service infusion in SMEs.

Finally, these findings extend existing knowledge about how manufacturing firms assimilate key capabilities and interact in business networks to infuse services. Research on service infusion to date has focused primarily on the internal organization of the firm (e.g., Gebauer 2008; Gebauer & Kowalkowski 2012; Kowalkowski, *et al.* 2012; Oliva & Kallenberg 2003; Raddats & Easingwood 2010), which ignores that many firms operate through service partners that also participate in service provision. Cova and Salle (2008), Matthyssens and Vandenbempt (2008), and Windahl and Lakemond (2006) suggest that relationships within a network are essential for many large, multinational manufacturing firms. We argue instead that the business network and its constellation of vertical and horizontal actors should be even more important for SMEs because of the vast, diverse capabilities needed for service provision. Although several SMEs charge for services through collaboration within their new value constellation, our findings also show that inflexibility in the business network can inhibit service infusion initiatives.

6.2 Managerial implications

In terms of managerial implications, we identify how different value constellations can create the resources that an SME needs to initiate and further develop the service infusion of its business. An SME adopting a service strategy can form different value constellations, whether to strengthen its present service strategy or to deliver a type of service outside its present service strategy. When an SME strengthens its present service strategy, one or more value constellations get initiated for each service. Value constellations form to ensure the capabilities needed to test, sell, and provide new services and to reduce the risk of the SME. Another alternative is that the formation of a new value constellation and access to external resources means that internal resources, previously tied up in basic services, such as skilled technicians, become available. The

resources then can be transferred to services within the existing service strategy of the firm, which often involves more advanced services.

A key issue for manufacturing firms is their ability to charge for services. Lay *et al.*'s (2010) empirical investigation of more than 3,000 manufacturing firms shows that the portion of services invoiced indirectly is larger than the directly invoiced portion. The ability to charge for services that had previously been free represents a challenge to managers (Pauwels & Weiss 2008). Our study shows that participation in a new value constellation can enable SMEs to start charging for their services. The introduction of new capabilities and enhanced offerings through a new value constellation into an ongoing business relationship changes the status and potential of the customer-provider relationship and can lead to a changed revenue model. Furthermore, an SME that offers new services, made possible through a new value constellation, is better positioned to charge for services, because the customer has not previously purchased the services nor is used to receiving them for free.

Ultimately, each SME must decide how to respond when it faces product commoditization: develop relationships with key actors in the business network, establish service revenue models, understand which key capabilities to acquire through collaboration with actors in the business network or acquisition, and form new vertically or horizontally integrated value constellations. To succeed with service infusion, it is seldom enough for the managers to change their mindset. Other actors in the value constellation(s) also must adapt and shift their mindset to some degree to achieve external alignment through mutual investments in reciprocal adaptation, such as trust and open dialogue (Kowalkowski 2011; Matthyssens & Vandenbempt 2008). Although SMEs face some disadvantages compared with large manufacturing firms, they also enjoy advantages, including a more entrepreneurial culture, a more flexible and agile organization, greater proximity to customers and partners, and better interfirm adaptability, which they should recognize and exploit.

Managing service infusion is a key strategic issue, not only for managers in multinational OEMs but also for an increasing number of SMEs. Regardless of whether an SME infuses services

proactively or reactively, its managers must be enterprising and aware of potential service provision opportunities; they must also recognize key challenges, such as the difficulties of allocating internal resources to work proactively and strategically with service infusion. If an SME has a better understanding of its service infusion options, it can better prepare its response to changes in its business network, including new customer needs, such that it can effectively acquire business-critical capabilities and expand its service business. It also should carefully assess possible service strategies and ways to organize interfirm relationships to achieve its objectives through service infusion.

6.3 Research limitations and further research

Our empirical investigation focused on the role of SMEs in the value constellation, and our data collection was limited to interviews and documents related to the focal actor. This approach was consistent with the stated purpose of identifying a range of value constellations, but more in-depth studies of all actors in the value constellations would create a better understanding of each value constellation. Furthermore, contrasting the present supplier perspective with a customer perspective could expand our existing knowledge.

In some cases, the firm interviews included only one key informant per firm, mainly because many SMEs make only a few people responsible for service provision. Further empirical investigations might include several layers of management to clarify the role of the different value constellations at strategic, tactical, and operational levels. In addition, we used a sample of Swedish SMEs, and though they all have multinational customers, the country-specific sample limits external validity. Additional empirical investigations should include samples from different cultural regions.

Finally, the nine generic value constellations we identified are not meant to be exhaustive but rather serve to highlight potential strategic opportunities for SMEs working with service provision. Other SMEs could construct other value constellations, a point that a larger-scale study could investigate further. The role of value constellations could be studied from a choice

perspective: All manufacturing firms must make such a decision when moving into services. The concept of value constellations also could apply to the choice large manufacturing firms make between providing some services in-house and others through external partners. Extending the value constellations to include both internal business units and external partners makes it possible to identify new types of value constellations.

Acknowledgments

The authors would like to thank Karolina Elmhester for her help to collect data in this study. This paper also benefits from the comments of three anonymous referees. The authors would also like to thank Region Värmland, the company cluster Steel & Engineering, and the Jan Wallander and Tom Hedelius Foundation for their support.

References

- Achrol, R. (1997). Changes in the theory of interorganizational relations in marketing: Toward a network paradigm. *Journal of the Academy of Marketing Science*, 25 (1), 56–71.
- Anderson, J.C., & Narus, J.A. (1995). Capturing the value of supplementary services. *Harvard Business Review*, 73 (1), 75–83.
- Araujo, L., Gadde, L-E., & Dubois, A. (2003). The multiple boundaries of the firm. *Journal of Management Studies*, 40 (5), 1255–1277.
- Baines, T., Lightfoot, H., Peppard, J., Johnson, M., Tiwari, A., Shehab, E., & Swink, M. (2009). Towards an operations strategy for product-centric servitization. *International Journal of Operations & Production Management*, 29 (5), 494–519.
- Bortoluzzi, G., Mazzurana, P., & Pittino, D. (2008). Entrepreneurial strategies within and across local systems: the network orchestrator figure. Working paper MOS, 2 (8), Udine, Italy: Department of Economics.
- Brady, T., Davies, A., & Gann, D. (2005). Creating value by delivering integrated solutions. *International Journal of Project Management*, 23 (5), 360–365.
- Chandler, A.D. (1990). *Scale and scope: The dynamics of industrial capitalism*. Cambridge, MA: Harvard University Press.
- Corsaro, D., Ramos, C., Henneberg, S.C., & Naudé, P. (2012). The impact of network configurations on value constellations in business markets: the case of an innovation network. *Industrial Marketing Management*, 41 (1), 54–67.
- Cova, B., & Salle, R. (2008). Marketing solutions in accordance with the S-D logic: co-creating value with customer network actors. *Industrial Marketing Management*, 37 (3), 270–277.
- Coviello, N.E., Brodie, R.J., Danaher, P.J., & Johnston, W.J. (2002). How firms relate to their markets: an empirical examination of contemporary marketing practices. *Journal of Marketing*, 66 (3), 33–46.
- Crant, J. M. (2000). Proactive behavior in organizations. *Journal of Management*, 26 (3), 435–462.
- Davies, A. (2004). Moving base into high-value integrated solutions: a value stream approach. *Industrial and Corporate Change*, 13 (5), 727–756.
- Davies, A., Brady, T., & Hobday, M. (2007). Organizing for solutions: Systems seller vs. systems integrator. *Industrial Marketing Management*, 36 (2), 183–193.

- Dubois, A., & Gibbert, M. (2010). From complexity to transparency: Managing the interplay between theory, method and empirical phenomena in IMM case studies. *Industrial Marketing Management*, 39 (1), 129–136.
- Dyer, J. H., & Nobeoka, K. (2000). Creating and managing a high-performance knowledge-sharing network: the Toyota case. *Strategic Management Journal*, 21 (3), 345–67.
- Edvardsson, B. (1996). Making service-quality improvement work, *Managing Service Quality*, 6 (1), 49–52.
- Eisenhardt, K. M. (1989). Building theory from case study research, *Academy of Management Review*, 14 (4), 532–550.
- European Commission (2003). Commission recommendation of 6 May 2003 concerning the definition of micro, small and medium-sized enterprises, *Official Journal of the European Union*, C(2003), 1422.
- Fang, E., Palmatier, R. W., & Steenkamp, J-B. E. M. (2008). Effect of service transition strategies on firm value, *Journal of Marketing*, 72 (September), 1–14.
- Fischer, T., Gebauer, H., Gregory, M., Ren, G., & Fleisch, E. (2010). Exploitation or exploration in service business development? Insights from a dynamic capabilities perspective. *Journal of Service Management*, 21 (5), 591–624.
- Ford, D. (2002). *Understanding business marketing and purchasing*. Padstow, UK: Thompson Learning.
- Ford, D. (2011). IMP and service-dominant logic: divergence, convergence and development. *Industrial Marketing Management*, 40 (2), 231–239.
- Ford, D., & Redwood, M. (2005). Making sense of network dynamics through network pictures: a longitudinal case study. *Industrial Marketing Management*, 34 (7), 648–657.
- Fundin, A., Witell, L., & Gebauer, H. (2012). Service transition: finding the right position on the goods-to-services continuum. *International Journal of Modeling in Operations Management*. 2 (1), 69–88.
- Gadde, L-E., Huemer, L., & Håkansson, H. (2003). Strategizing in industrial networks, *Industrial Marketing Management*, 32 (5), 357–364.
- Galbraith, J. R. (2002). Organizing to deliver solutions. *Organizational Dynamics*, 31 (2), 194–207.

- Gebauer, H. (2008). Identifying service strategies in product manufacturing companies by exploring environment-strategy configurations. *Industrial Marketing Management*, 37 (3), 278–291.
- Gebauer, H., Edvardsson, B., Gustafsson, A., & Witell, L. (2010a). Match or mismatch: strategy-structure configurations in the service business of manufacturing companies. *Journal of Service Research*, 13 (2), 184–197.
- Gebauer H., Gustafsson, A., & Witell, L. (2011). Competitive advantage through service differentiation by manufacturing companies. *Journal of Business Research*, 64 (12), 1270–1280.
- Gebauer, H. and Kowalkowski, C. (2012), Customer-focused and service-focused orientation in organizational structures, *Journal of Business & Industrial Marketing*, 26 (7) (in press).
- Gebauer, H., Paiola, M., & Edvardsson, B. (2010b). Service business development in small and medium capital goods manufacturing companies. *Managing Service Quality*, 20 (2), 123–139.
- Gibbert, M., Ruigrok, W., & Wicki, B. (2008). What passes as a rigorous case study? *Strategic Management Journal*, 29 (13), 1465–1474.
- Gomes-Casseres, B. (1994). Group versus group: how alliance networks compete. *Harvard Business Review*, 72 (4), 62–74.
- Grönroos, C. (2006). Adopting a service logic for marketing. *Marketing Theory*, 6 (3), 317–333.
- Gummesson, E. (2006). Many-to-many marketing as grand theory: a Nordic School contribution. In S.L. Vargo, & R.F. Lusch (Eds.), *The Service-Dominant Logic of Marketing: Dialog, Debate, and Directions* (pp. 339–353). New York: Sharpe.
- Gustafsson, A., Brax, S., & Witell, L. (2010). Setting a research agenda for service business in manufacturing industries. *Journal of Service Management*, 21 (5), 557–563.
- Hallén, L., Johanson, J., & Seyed-Mohamed, N. (1991). Interfirm adoption in business relationships. *Journal of Marketing*, 55 (April), 29–37.
- Håkansson, H., Ford, D., Gadde, L.-G., Snehota, I., & Waluszewski, A. (2009). *Business in networks*. London, UK: John Wiley & Sons.
- Håkansson, H., & Ford, D. (2002). How should companies interact in business networks? *Journal of Business Research*, 55 (2), 133–139.

- Håkansson, H. & Snehota, I. (2006). No business is an island: The network concept of business strategy. *Scandinavian Journal of Management*, 22 (3), 256–270.
- Håkansson, H., & Snehota, I. (1995). *Developing relationships in business networks*. London, UK: Routledge.
- Hinterhuber, A. (2002). Value chain orchestration in action and the case of the global agrochemical industry. *Long Range Planning*, 35 (6), 615–635.
- Hobday, M., Davies, A., & Prencipe, A. (2005). Systems integration: a core capability of the modern corporation. *Industrial and Corporate Change*, 14 (6), 1109–1143.
- Jacob, F., & Ulaga, W. (2008). The transition from product to service in business markets: an agenda for academic inquiry. *Industrial Marketing Management*, 37 (3), 247–253.
- Järvensivu T., Törnroos J-A. (2010). Case study research with moderate constructionism: Conceptualization and practical illustration. *Industrial Marketing Management*, 39 (1) 100–108.
- Jaworski, B., Kohli, A., & Sahay, A. (2000). Market-driven versus driving markets. *Journal of the Academy of Marketing Science*, 28 (1), 45–54.
- Kindström, D., (2010). Towards a service-based business model: key aspects for future competitive advantage. *European Management Journal*, 28 (6), 479–490.
- Kotler, P. (1991). *Marketing management: analysis, planning, implementation, and control*. Englewood Cliffs, NJ: Prentice Hall.
- Kowalkowski, C. (2011). Dynamics of value propositions: insights from service-dominant logic, *European Journal of Marketing*, 45 (1/2), 277–94.
- Kowalkowski, C., Kindström, D., Alejandro, T.B., Brege, S., & Biggemann, S. (2012). Service infusion as agile incrementalism in action. *Journal of Business Research*, 65 (6), 765-772.
- Kowalkowski, C., Kindström, D., & Witell, L. (2011a). Internalisation or externalisation? Examining organisational arrangements for industrial services. *Managing Service Quality*, 21 (4), 373–391.
- Kowalkowski, C., Kindström, D., & Brehmer, P.-O. (2011b). Managing industrial service offerings in global business markets. *Journal of Business & Industrial Marketing*, 26 (3), 181–192.
- Internalisation or externalisation? Examining organisational arrangements for industrial services. *Managing Service Quality*, 21 (4), 373–391.

- Lay, G., Copani, G., Jäger, A., & Biege, S. (2010). The relevance of service in European manufacturing industries. *Journal of Service Management*, 21 (5), 715–726.
- Levitt, T. (1980). Marketing success through differentiation of anything. *Harvard Business Review*, 59 (1), 83–92.
- Lieberman, M. B., & Montgomery, D. B. (1998). First-mover advantages. *Strategic Management Journal*, 9 (Summer), 41–58.
- Lindgreen, A., & Wynstra, F. (2005). Value in business markets: What do we know? Where are we going? *Industrial Marketing Management*, 34 (7), 732–748.
- Löfberg, N., Witell, L., & Gustafsson, A. (2010). Service strategies in a supply chain. *Journal of Service Management*, 21 (4), 427–440.
- Lorange, P., & Roos, J. (1992). *Strategic alliances: Formation, implementation, and evolution*. Cambridge, MA: Blackwell.
- Lorenzoni, G., & Lipparini, A. (1999). The leveraging of interfirm relationships as a distinctive organizational capability: a longitudinal study. *Strategic Management Journal*, 20 (4), 317–38.
- Lusch, R.F., Vargo, S.L., & Tanniru, M. (2010). Service, value networks and learning. *Journal of the Academy of Marketing Science*, 38 (1), 19–31.
- Lytle, R.S., Hom, P.W., & Mokwa, M.P. (1998). SERV*OR: A managerial measure of organizational service-orientation. *Journal of Retailing*, 74 (4), 455–489.
- Malleret, V. (2006). Value creation through service offers. *European Management Journal*, 24 (1), 106–116.
- Martin, C. R., & Horne, D. A. (1992). Restructuring towards a service orientation: The strategic challenges. *International Journal of Service Industry Management*, 3 (1), 25–38.
- Mathieu, V. (2001). Service strategies within the manufacturing sector: benefits, costs and partnership. *International Journal of Service Industry Management*, 12 (5), 451–475.
- Matthyssens, P., & Vandenbempt, K. (2008). Moving from basic offerings to value-added solutions: strategies, barriers and alignment. *Industrial Marketing Management*, 37 (3), 316–328.
- Matthyssens, P., & Vandenbempt, K. (2010). Service addition as business market strategy: identification of transition trajectories. *Journal of Service Management*, 21 (5), 693–714.

- Meredith, J. (1998). Building operations management theory through case and field research. *Journal of Operations Management*, 16 (4), 441–454.
- Miller, D. (1996). Configurations revisited. *Strategic Management Journal*, 17 (7), 505–512.
- Möller, K., & Rajala, A. (2007). Rise of strategic nets: new modes of value creation. *Industrial Marketing Management*, 36 (7), 895–908.
- Möller, K. & Svahn, S. (2006). Role of knowledge in value creation in business nets. *Journal of Management Studies*, 43 (5), 985–1007.
- Möller, K., & Törrönen, P. (2003). Business suppliers' value creation potential: a capability-based analysis. *Industrial Marketing Management*, 32 (2), 109–118.
- Narver, J. C., Slater, S. F., & MacLachlan, D. L. (2004). Responsive and proactive market orientation and new-product success. *Journal of Product Innovation Management*, 21 (5), 334–347.
- Neely, A. (2008). Exploring the financial consequences of the servitization of manufacturing. *Operations Management Research*, 1 (2), 103–118.
- Neu, W. A., & Brown, S. W. (2005). Forming successful business-to-business services in goods-dominant firms. *Journal of Service Research*, 8 (1), 3–17.
- Nilsson, L., Gustafsson, A., & Johnson, M. (2001). The impact of quality practices on customer satisfaction and business results: product vs. service organizations. *Journal of Quality Management*, 6 (1), 5–27.
- Normann, R., & Ramírez, R. (1993). From value chain to value constellation: designing interactive strategy. *Harvard Business Review*, 71 (4), 65–77.
- Normann, R., & Ramírez, R. (1994). *Designing interactive strategy: From value chain to value constellation*. Chichester, UK: John Wiley & Sons.
- Oliva, R., & Kallenberg, R. (2003). Managing the transition from products to services. *International Journal of Service Industry Management*, 14 (2), 160–172.
- Ostrom, A. L., Bitner, M. J., Brown, S.W., Burkhard, K., Goul, M., Smith-Daniels, V., Demirkan, H., & Rabinovich, E., (2010). Moving forward and making a difference: Research priorities for the science of service. *Journal of Service Research*, 13 (1), 4–36.
- Pauwels, K., & Weiss, A. (2008). Moving from free to fee: how online firms market to change their business model successfully. *Journal of Marketing*, 72 (3), 14–31.

- Penttinen, E., & Palmer, J. (2007). Improving firm positioning through enhanced offerings and buyer-seller relationships. *Industrial Marketing Management*, 36 (5), 552–564.
- Peterson, H.C., Wysocki, A., & Harsh, S.B. (2001). Strategic choice along the vertical coordination continuum. *International Food and Agribusiness Management Review*, 4 (2), 149–166.
- Podolny, J. M., & Page, K. L. (1998). Network forms of organization. *Annual Review of Sociology*, 24, 57–76.
- Porter, M. E. (1998). *Competitive strategy: techniques for analyzing industries and competitors*. New York: The Free Press.
- Prencipe, A., Davies, A., & Hobday, M. (2003). *The business of systems integration*. New York: Oxford University Press.
- Raddats, C. (2011). Aligning industrial services with strategies and sources of market differentiation, *Journal of Business & Industrial Marketing*, 26 (5), 332–343.
- Raddats, C., & Easingwood, C. (2010). Services growth options for B2B product-centric businesses. *Industrial Marketing Management*, 39 (8), 1334–1345.
- Ramírez, R. (1999). Value co-production: intellectual origins and implications for practice and research. *Strategic Management Journal*, 20 (1), 49–65.
- Ramírez, R., & Wallin, J. (2000). *Prime movers: Define your business or have someone define it for you*. Chichester, UK: John Wiley and Sons.
- Siggelkow, N. (2007). Persuasion with case studies. *Academy of Management Journal*, 50 (1), 20–24.
- Storey, D., & Greene, F. (2010). *Small business and entrepreneurship*. Harlow, UK: Financial Times/Prentice Hall.
- Stoughton, M., & Votta, T. (2003). Implementing service-based chemical procurement: lessons and results. *Journal of Cleaner Production*, 11 (8), 839–849.
- Trautwein, F. (1990). Merger motives and merger perceptions. *Strategic Management Journal*, 11 (4), 283–295.
- Tukker, A., & Tischner, U. (2006). Product-services as a research field: past, present and future. Reflections from a decade of research. *Journal of Cleaner Production*, 14 (17), 1552–1556.

- Tuli, K. R., Kohli, A. K., & Bharadwaj, S. G. (2007). Rethinking customer solutions: from product bundles to relational processes. *Journal of Marketing*, 71 (July), 1–17.
- Ulaga, W., & Eggert, A. (2006). Value-based differentiation in business relationships: gaining and sustaining key supplier status. *Journal of Marketing*, 70 (1), 119–136.
- Ulaga, W., & Reinartz, W.J. (2011). Hybrid offerings: how manufacturing firms combine goods and services successfully. *Journal of Marketing*, 75 (4), 5–23.
- Ulaga, W., Sharma, A., & Krishnan, R. (2002). Plant location and place marketing: understanding the process from the business customer's perspective. *Industrial Marketing Management*, 31 (4), 393–401.
- Vandermerwe, S., & Rada, J. (1988). Servitization of business: Adding value by adding services. *European Management Journal*, 6 (4), 314.
- Windahl, C., & Lakemond, N. (2006). Developing integrated solutions: the importance of relationships within the network. *Industrial Marketing Management*, 35 (7), 806–816.
- Windahl, C., & Lakemond, N. (2010). Integrated solutions from a service-centered perspective: applicability and limitations in the capital goods industry. *Industrial Marketing Management*, 39 (8), 1278–1290.
- Wise, R., & Baumgartner, P. (1999). Go downstream: the new profit imperative in manufacturing. *Harvard Business Review*, 77 (5), 133–141.
- Yin, R. K. (2003). *Case study research: Design and methods*. Thousand Oaks, CA: Sage Publications.

Tables

Table 1. SMEs in the study.

Firm	Turnover	Employees	Services infused	Underlying product offerings	Network collaboration
Acoustica Ltd.	€2.6m	22	Noise-reducing solutions, acoustic calculations, technical reports	Noise control materials and products	Close cooperation with external specialist, sales agents in China and India
Alu Ltd.	€24m	155	Systems for vehicles	Details for the automotive industry	Close informal cooperation, joint testing, and development with manufacturers to provide systems
Contract Mfg. Ltd.	€20.2m	98	Codevelopment and testing; short-term hiring of specialists	Contract manufacturing of sheet metal articles, including construction	Development work and formal collaboration with customers, collaboration with component and material suppliers
Dredge&Dig Ltd.	€6.5m	54	Logistics services, process design and optimization, calculations of stresses, information and billing services	Wear parts for excavators and loaders, wear parts systems to dredge harbors and shipping channels	Multilevel manufacturing and sales collaboration with partner firm, product complementary collaboration, R&D collaboration with global partner firm
Hydro Power Ltd.	€18.9m	37	Turnkey operations (overhaul, upgrading, and modernization of water turbines)	Integrated automation systems, spare parts, trailing wheels, and other components	Recurring short-term agreements with service and component suppliers and foundries
Inertia Ltd.	€1m	15	Electronics, electromechanic, and software development services	Inertia calculators	Close cooperation with other manufacturers to provide systems. Recurring, informal cooperation with firms with complementary competences.
Mill Service Ltd.	€24.0m	120	Maintenance outsourcing and on-site services	Components and spare parts to rolls and other equipment	Close cooperation with customers and with industry experts to tackle more specialized maintenance needs
Pipe Ltd.	€2.4m	5	Welding, transport, and assembly services	Quick coupling pipes, pipe fittings and couplings	Close collaboration, co-location, and integrated operations with sister company (after merger) and independent workshop
Surface Ltd.	€1.4m	17	Assembly, packing, and direct delivery to	Surface conditioning and industrial	Close informal co-operation with manufacturers

			external customers.	painting	
Tankhouse Technology Ltd.	€45.3m	37	Customer training, maintenance plans	Construction of deposit stripping machines for electrolytic refining (including on-site assembly), spare parts	Development work with key customers, close cooperation with component and machine suppliers to ensure quality
Turnkey Ltd.	€5.0m	15	Turnkey solutions: design, construction, manufacturing, welding, and assembly of power boilers; process calculations and analyses, customer training	Manufacturing and welding of power boilers, pressure vessels, manholes, heat exchangers, etc.	Recurring, informal supplier cooperation, multilevel collaboration with large customers, vertical backward integration through acquisitions of manufacturing firms
Valve Ltd.	€1.0m	23	Maintenance plans, customer training	Control- and on/off-valves from acid-proof stainless steel	Collaboration with multinational product and service partners to provide systems. Contingent value constellations: different actors can take integrator roles
Wrecker Ltd.	€3.5m	17	Online marketplace (service platform)	Tow equipment for tow trucks, customized construction, assembly, spare parts	Strong reputation and trust among customers, but informal. Formal, short-term collaboration required for online service

Table 2. Overview of value constellations for service provision.

Value constellation	Case firms	Key objectives	Key capabilities (Brady et al. 2005; Fischer et al. 2010; Möller & Törrönen, 2003)	Service strategies (Gebauer, 2008; Gebauer et al. 2010)	Market orientation (Crant, 2000; Jaworski et al. 2000)	Mode of coordination (Lorange & Roos, 1992; Peterson et al. 2001)	Integration (Chandler, 1990)	Interfirm adaptation (Hallén et al. 1991)
Systems integration	Alu, Contract Mfg., Hydro Power, Inertia, Tankhouse Technology, Turnkey	Develop customer relationships, increase customer share of wallet	Production, network, systems integration, process improvement capability	All five configurations possible	Reactive	From informal, verbal to formal agreement	Vertical	Unilateral
C-to-C intermediary	Wrecker	Customer loyalty	Relationship, IT, market channel position	After-sales service provider	Proactive	Formal, short-term relationship	Vertical	Unilateral
Competence co-location	Mill Service	Develop customer relationships, forwards integration in line with firm's strategic objectives	Service process (including capacity utilization, service sales, MRO), relationship capability	Outsourcing partner	Reactive and proactive	Multilevel, formal, long-term relationship	Vertical	Reciprocal
Specialist externality	Acoustica	Charge for services, become a knowledge provider	Relationship, incremental innovation capability	Development partner	Proactive	Formal agreement, close relationship	Horizontal	Reciprocal
Shared service platform	Dredge&Dig	Best product quality on the market	Relationship, radical innovation capability	After-sales and customer support service provider	Proactive	Formal agreement	Horizontal	Reciprocal
Dual customer contact partnership	Dredge&Dig, Surface	Deliver product system, access to new market	Relationship, systems integration capability	After-sales and customer support service provider	Proactive	From informal to multi-level, formal agreement	Horizontal and vertical	Reciprocal
Horizontal collaboration	Dredge&Dig, Inertia, Valve	More competitive (product) supplier	Relationship/network capability	Customer service strategy, after-sales service provider, development partner	Reactive and proactive	Informal, verbal agreement, close relationship	Horizontal	Reciprocal (to a low extent)
Integration co-location	Pipe	Access to new customers, systems selling	Relationship, delivery, production capability	After-sales service provider	Proactive	Merger and close, informal relationship	Horizontal and vertical	Reciprocal
Competence acquisition	Hydro Power, Mill Service, Turnkey	New competences, increased control, manufacturing capacity, develop customer relationships	Relationship, process improvement capabilities	Customer support service provider, outsourcing partner, development partner	Proactive	Acquisition	Horizontal and vertical	Reciprocal

Figures

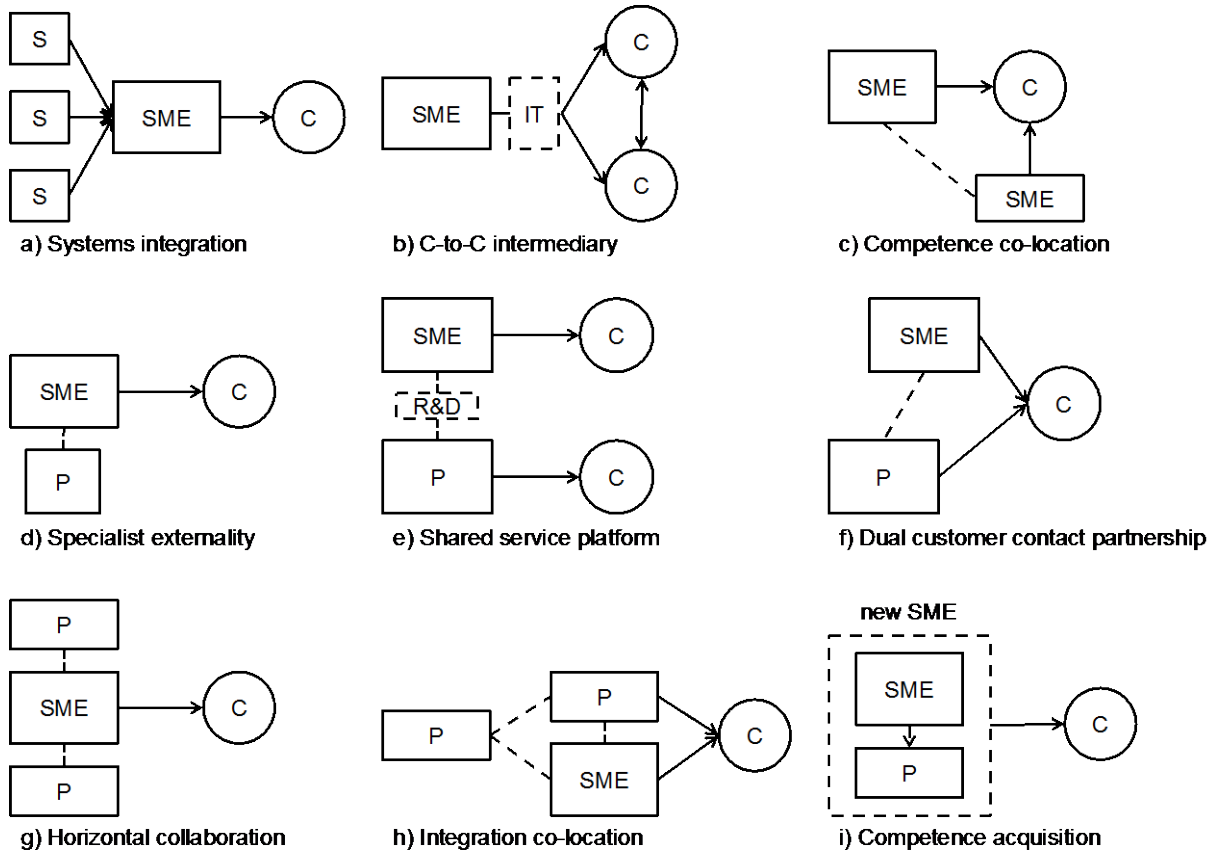

Legend: SME = Small- and medium-sized enterprise, S = Supplier, C = Customer, P = Partner

Figure 1. Value constellations for service provision.