

Sebastian Cedrick Johansen

Henrik Kjærvik

BI Norwegian Business School  
Preliminary Thesis Report

# Digitalization of the Construction Industry: Implementation of BIM in the Execution Phase.

Hand-in date:

15.01.2018

Campus:

BI Oslo

Examination code and name:

GRA 19502 Preliminary thesis report

Programme:

Master of Science in Business, Major in Strategy

Supervisor:

Ragnhild Kvålshaugen

## Table of Contents

Summary.....	3
<b>1. Research background .....</b>	<b>4</b>
<i>1.1 The construction industry .....</i>	4
<i>1.2 The BIM-technology .....</i>	4
<b>2. Resource issues .....</b>	<b>5</b>
<i>2.1 Different types of construction projects .....</i>	5
<i>2.2 No general productivity or performance metric .....</i>	6
<i>2.3 Limited research conducted previously.....</i>	6
<b>3. Resource Statement.....</b>	<b>6</b>
<i>3.1 Resource question .....</i>	6
<i>3.2 Resource objectives .....</i>	7
<i>3.3 Relevance of the topic .....</i>	7
<b>4. Literature Review .....</b>	<b>8</b>
<i>4.1 Institutional-based view .....</i>	8
<i>4.2 Strategic Change .....</i>	9
<i>4.3 Sociomateriality .....</i>	12
<b>5. Research Design .....</b>	<b>13</b>
<i>5.1 Case Study .....</i>	14
<i>5.2 Primary Data.....</i>	15
<i>5.3 Secondary Data .....</i>	17
<i>5.4 Validity and Reliability .....</i>	17
<b>6. Motivation.....</b>	<b>19</b>
<b>7. Timetable .....</b>	<b>20</b>
<b>References.....</b>	<b>21</b>
<i>Articles.....</i>	21
<i>Books .....</i>	24
<i>Reports.....</i>	25
<i>Web pages.....</i>	25

## Summary

This preliminary thesis report will form the basis for our master thesis. The aim of our thesis is to investigate the use of BIM stations on-site in a construction project, and the effects this will have on project activities and productivity. Our research question is:

*How will the implementation of BIM (Building Information Modelling) at the construction site affect the execution phase of the construction process?*

The main objectives we will investigate in order to answer our research questions are:

- How will the implementation of BIM stations at the construction site affect the efficiency and productivity of a project?
- How are the processes and activities performed at the construction site affected by a more significant use of BIM on-site?
- How will key activities at the construction site change in terms of importance and nature?

We will use triangulation, a mix between qualitative and quantitative methods, where our quantitative outcomes function as support for our qualitative results, which will be our main focus. Our primary source of data will come from conducting a case study of Veidekke's project in Nydalen, including interviews, participant observation and a questionnaire survey.

Our first step will be to gather information about the technology, as well as more in-depth material on the case in question. We will then process this information, and complete our theoretical framework, before constructing interview- and survey schemas. Further, we will provide an overview of relevant interview objects, which will be followed by conducting the interviews and sending out the questionnaire surveys.

# 1. Research background

## *1.1 The construction industry*

The construction industry is known as the construction of buildings and infrastructure, which entails the construction of railways, homes, shopping malls, airports, universities, roads, water and sewer lines etc. The industry is important for economies as it has strong influence on the GDP and employment rate (National Research Council, 2009). The construction industry can be divided into two phases, the planning or design phase, and the construction or execution phase (Bråthen & Moum 2015). Our paper will primarily focus on the latter.

The productivity in the industry is challenging to measure, and there is no general productivity metrics for the construction industry (National Research Council, 2009). One of the reasons why it is difficult to measure, is because it is divided into 4 segments; residential, commercial/institutional, industry and infrastructure (Huang et al. 2009), which has significant differences in terms of cost level, expected building time etc. However, the productivity in the construction industry generally describes how well, how quick and to which cost buildings and infrastructure can be constructed (National Research Council, 2009).

## *1.2 The BIM-technology*

BIM is a digital representation of physical and functional characteristics of a facility, traditionally used as a tool in the planning phase of a construction project. However, in recent years it has been applied more often in the execution phase as well (Murvold et al. 2016). Several contractors have stated that BIM leads to less errors and rework, lower costs, and increased collaboration (Cant, 2014). This paper will be focused on BIM stations, which are computers placed at the construction site where the workers can access the information they seek (Murvold et al. 2016).

Hewage & Ruwanpura (2006) discovered a demand from the workers for a mobile, real-time information source on site. The on-site workers wanted the opportunity to view 3D and up-to-date drawings, as well as accessing information relevant for the project, such as weather updates, safety information or technical information. Ruwanpura et al. (2012) conducted a research on the i-Booth. This is

an on-site communication framework designed to provide the workers with material management, updated drawings and work demonstrations. This innovation turned out to have a positive effect on productivity and worker satisfaction. Davies & Harty conducted in 2013 a case study of the use of mobile tablets at construction sites, these was called “SiteBIM”. These tablets were intended to provide the workers with updated versions of the BIM model. The results of this study indicated that the SiteBIM had a positive influence on the performance of the construction project, in terms of waste and less growth in the cost of service installations.

Atkinson (1998) highlights poor communication as one of the main sources to errors in the execution phase. On-site BIM stations and tablets has been shown to improve this error, as this technology increase the accessibility of updated information and drawings in a less time-consuming matter (Harstad et al. 2015). A challenge in the implementation of the on-site BIM stations is the significant resistance towards new technology in the construction industry (Brodie & Perry 2001; Scott et al. 1994). The resistance from a worker, increase with his age and experience within the field (Hewage et al. 2008). Hardin (2011) argues for the importance of sufficient training when using the BIM in the execution phase. Bråthen & Moum (2015) explained how Skanska launched a training program were the firm's BIM coordinator provided the workers with sufficient knowledge in how to use BIM in their work day.

There is still a limited amount of research on the use of BIM on-site, and new cases and perspectives are important to cover the knowledge gap.

## **2. Resource issues**

### ***2.1 Different types of construction projects***

As mentioned earlier is the construction industry very large. It is defined as the construction of all buildings and infrastructure. Even when we divide the industry into the four segments; residential, industry, commercial/institutions, and infrastructure, will the different projects have a high degree of inequalities (National Research Council, 2009). These differences arise from size, budget,

available tools and machines, location etc. The high degree of inequalities within the segments make it challenging to compare the projects.

### ***2.2 No general productivity or performance metric***

It is challenging to measure performance and productivity in the construction industry, and it has not been developed a general productivity metric. (National Research Council, 2009). We have yet to decide for a productivity metric, and will investigate this further.

### ***2.3 Limited research conducted previously***

The use of BIM on the construction site is still in early phases, and there has been conducted a limited amount of research on this. Also, one of our chosen perspectives, the sociomateriality approach, is in its infancy. The challenge combined with this is the fact that we cannot use previous literature as fundamental guidance to the same degree as if we have conducted the research in more traditional fields.

## **3. Resource Statement**

In our thesis, we will look at the use of BIM on-site. We will examine the consequences of applying BIM in the execution phase. We will conduct a case study of Veidekke, and look at two projects with similar characteristics in Nydalen, but with different degree of use of BIM in the execution phase.

### ***3.1 Resource question***

We have formulated a research question which this paper will investigate and try to answer. The research question derives from the knowledge gap that exist in the literature regarding on-site utilization of BIM and BIM stations. Our research question is phrased as follows:

*How will the implementation of BIM (Building Information Modelling) at the construction site affect the execution phase in the construction process?*

The purpose is to investigate what happens when a firm decides to utilize BIM in the execution phase. We seek to identify the changes in processes and productivity caused by BIM. However, we have yet to decide what productivity metric we seek to use in our paper.

### ***3.2 Resource objectives***

In our research, we have a few research objectives we will investigate to able to answer our research question.

- How will the implementation of BIM stations at the construction site affect the efficiency and productivity of a project?
- How are the processes and activities performed at the construction site affected by a more significant use of BIM on-site?
- How will key activities at the construction site change in terms of importance and nature?

We will investigate if BIM will decrease the amount time spent on waiting due to lack of communication or slow decision-making processes. Our paper will also examine if the amount of errors and rework decrease when utilizing the BIM stations. Furthermore, we will compare actual time and costs spent on the project with the predicted building-time and costs. However, as mentioned, we yet to specifically decide which metrics to use.

### ***3.3 Relevance of the topic***

The literature is limited regarding the use of BIM on-site, however we aim to complement the existing literature by studying what effect the implementation of the technology has on a project, by conducting a case study. The use of BIM at the construction site has in recent years increased, and we seek to mitigate the knowledge gap that exist regarding the utilization of BIM on-site.

## 4. Literature Review

In this section, we will provide a literary review, presenting the theories and models that is relevant to our research questions, as well as the associated research objectives. By providing a strong grounding in related literature, and identify gaps in the research, we will be better able to deliver comprehensive empirical research. (Eisenhard, Graebner, 2007) To avoid uncertainty regarding certain ideas, this section will also contain definitions of key concepts and notions, as some are prone to interpretation.

To best capture the essence of our research question and objectives, we will in this literary review focus on the concept of sociomateriality; the assumption that technology and organizational activities are inseparable, the institutional based view; in which performance differences are explained by an organization's laws, rules and routines, as well as the concept of strategic change, specifically aimed at the synergy between technology, organization, their processes, strategy, and people, and the importance and effects of innovation implementation. We believe that by using the concepts of sociomateriality, institutional based view and strategic change we will be able to better understand the consequences and effects implementing new technology will have on the organization's activities, as this is the core of our research question.

### *4.1 Institutional-based view*

Douglass North (1991) describes institutions as “the humanly constraints which structure human interactions”. Peng et al. (2013) highlights that the institutional based view is as the third major theory in strategy. This theory considers the formal and informal institutions, which make the boundaries of the organization, as the source to performance differences. Examples of formal institutions are laws, regulations and rules, while norms, culture and ethics are examples of informal institutions Peng et al. (2013) contributes with two propositions where the first argue that actors pursue their interests within the framework given by the institutions. The second proposition argues that where there is a lack of formal constraints, the informal constraints will play a bigger role.



Börner and Verstagen (2011) highlights how firms' and employees' actions are influenced by the institutionalized routines and norms in a firm, but at the same time argue that the informal institutions are affected by the actions performed by the firm or its organization. This creates a mutual influential relationship between the actors and institutions. This relationship describes a process of change, however in many situations is the organization resistant for change.

LaPlante (1991) provides empirical examples where technological implementations suffers from resistance for change within the organization. One example she provides is from Premier Hospital Inc. in Illinois, where the hospital manager attempts to introduce a computer based booking system for conference rooms at the hospital. However, while the technology works without any problems, the manager is unable to fully implement this system, because the employees refuse to use it, and instead continue using the old manual system. In this example, the manager discovered that a successful implementation of new technology depends not only on the technology, but also on the reception by the employees. Börner and Verstagen (2011) confirms this, stating that once the resistance to change is overcome, routines change more easily.

#### ***4.2 Strategic Change***

The ever-changing environment in today's business world require companies to extend their conventional approach to change (Hsiao & Ormerod, 1998). The emergence and implementation of radically new technology, such as BIM, is forcing organizations to transform themselves into adaptive enterprises, as the "*old-rules of the game*" don't apply anymore (Tidd & Pavitt, 2005). In order to effectively manage their critical success factors, affected by the complexity and uncertainty of the new technology, the firm needs to establish synergy between technology, organization, processes, strategy, and people (Hsiao & Ormerod, 1998). These are some of the reasons why it is critical for firms in the construction industry to be able to manage and enable strategic change.

During the last decades, there has been several attempts at defining strategic change. Greiner and Bhambri (1989) defined strategic change as a "*shifting interplay between deliberate and emergent processes (...) leading to major changes in strategy and/or organization, which result in a realignment between*

*the firm and its environment*". Later, Wiersema and Bantel (1992) were to define it as an absolute change in product diversification level, while Giola et al. (1994) argued that it *"involved a redefinition of organizational mission and purpose or a substantial shift in overall priorities and goals to reflect new emphases or direction"*.

For the aim of this research, however, we have chosen to follow Rajagopalan and Spreitzer's (1997) definition: *"Strategic change represents a radical organizational change that is consciously initiated by top managers, creating a shift in key activities or structures that goes beyond incremental changes to pre-existing processes"*. They later added that this change must be in alignment with its external environment. This definition clearly defines strategic change as a "radical" change, rather than an incremental or "ordinary" change. According to Hopkins (1987), a strategic change can be viewed as "radical" if: (a) the change is significantly different from how the organization previously did business; (b) the change has far-reaching effects; (c) the change affects the emotional state of organizational members, creating insecurity and uncertainty. We believe that the implementation of BIM in the execution phase of the construction process fits well into these definitions of both strategic change and radical change.

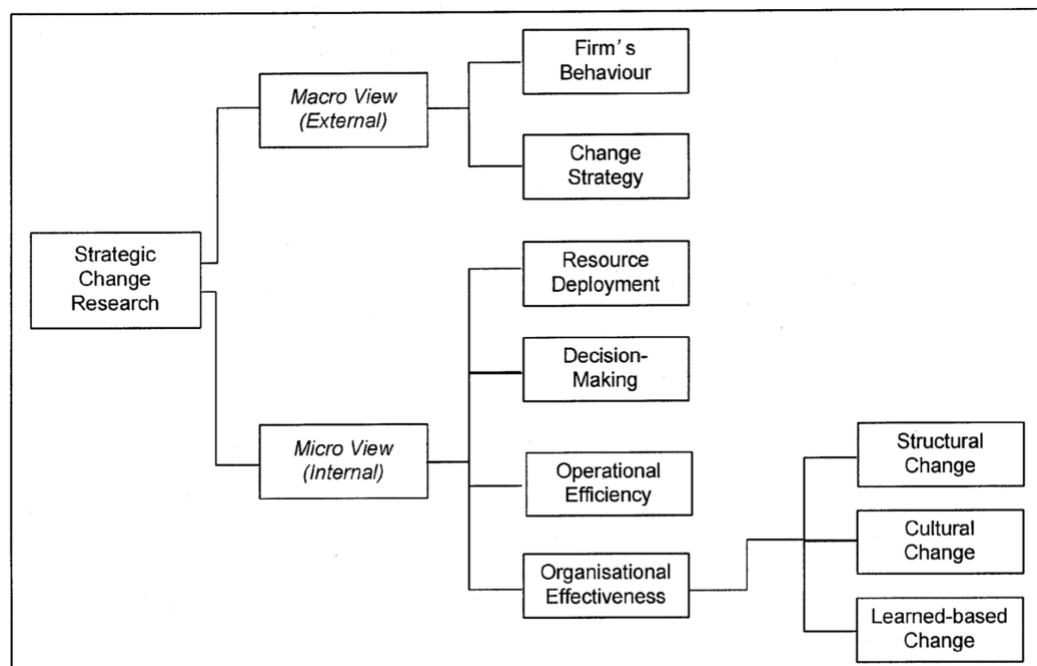

Pettigrew (1988) created an overview of the strategic change literature, which later was adapted by Hsiao & Ormerod (1998) (See figure 1). They divided the literature into macro and micro perspectives, which further resulted in six sub-categories. In order to restrict the extent of our research, we have chosen to focus on the categories we found to be most relevant concerning our research question. Consequently, our main focus will be on the sub-category “*Operational Efficiency*”, as well as key insights from the macro perspective on “*Firm’s Behaviour*”.

Hsiao & Ormerod (1998) explained that the purpose of the macro perspective was to “*understand how firms link competitive performance to their abilities to adapt to major changes in their environment*”. Further, it aims to analyse how an organization manage major external changes, such as industry-wide adaption of new technology.

Looking at operational efficiency, Hsiao & Ormerod (1998) states that it “*analyses strategic change through the rejuvenation of a firm’s process by improvement and innovation*”. Improvement focus on incremental change in order to improve already existing processes. Innovation, however, engages in what is termed “redesign” or “reengineering”, referring to the abandonment of existing methods to participate in radical reforms. In other words, it tries to break away from the old rules and assumptions about how to organize and conduct business. Hammer (1990) stresses that reengineering, or process innovation, should be both broad and cross-functional in scope.

In his book, Davenport (1993) addresses the importance of technology as an enabler of process innovation, and its implications for key business processes. However, many researchers are critical to the actual impact of an investment in innovation and new technology. Morton (1991) found a negative correlation between technology investment and productivity/profitability, while others (Loveman, 1994; Baily, 2011), found no significant gains at all. Davenport (1993) addressed these results by stressing that to really benefit, there needs to be a change in a process, and that the role of technology is to make new process designs available. Hammer (1990) supports this by stating that “*the organization*

*should not use technology to automate an existing process, but to enable a new one”.*

Davenport (1993) further suggest nine different opportunities enabled by process innovation, which presume the business objectives of time efficiency, reduction of cost, etc. One of these opportunities are the informational impact, in which technology can be used within a process to capture information about process performance. A second opportunity is the analytical impact, where this information need to be analysed. Further opportunities are automational, sequential, tracking, geographical, integrative, intellectual and disintermediating.

### ***4.3 Sociomateriality***

The sociomateriality approach address the assumption that the organization, activities and technology should be looked at separately, and argues that there is an inseparability between the social and technical aspect (Orlikowski & Scott, 2008). This approach, with other words, looks at the social and the material as inextricably related, were there could be no material without the social, and no social which is not also material (Orlikowski 2007).

The traditional organizational literature on materiality tends to either ignore the role of materiality in the organizational life, or just to study specific cases of use of technology and material. By only looking at materiality under special circumstances we ignore the role of materiality in the everyday life of an organization. This is a weakness in the literature because organizations and its employees interact with materiality and technology all the time and not once in a while or under specific circumstances. The materiality aspect of an organization affects the organization and its employees (Orlikowski, 2007).

Orlikowski (2007) argued for this approach by providing two empirical cases. One of these examples was how researchers interact with Google´s technology, PageRank. She argues that the PageRank technology in information search affects how researchers´ look for information, while the researchers influence the results provided by PageRank and Google´s search engine. PageRank would have no value if no researcher´s used it, as it continuously is updated with the searching activities. Equally would the researchers´ product be of no value if there would be

no search engine. The researching activities could not be divided from the technology. This illustrates the core of sociomateriality, that the materiality and the social should be treated as inextricable.

Reich, Rooney & Hopwood conducted in 2017 a research looking at emergent learning at work with a sociomaterial perspective. They looked at three cases, one of whom were at a railway construction site. They argued that the role of blueprints is not only as guidance and a future plan for the construction, but blueprint will also be changed continuously with the site-walks and situations at the construction site. This sociomaterial view of blueprints is valuable and highly relatable for the purpose of this paper.

Even though more research has been conducted in the field of sociomateriality in recent years, the approach is still in its infancy and has therefore also received limited attention (Akhlaghpour et al. 2013). There is a need for further research in this field because it lacks depth and presence. The theory has to be applied and investigated in more projects and case studies.

## **5. Research Design**

For our thesis, we have decided to use a mix between qualitative and quantitative methods. More specifically, the main focus of our study will be on qualitative results, however, by including quantitative results we will be able to improve our overall outcomes. In quantitative methods theory drives the formulation of the research questions, which leads the collection of data, which in turn adds to the existing theory (Bryman & Bell 2015). Qualitative research, on the other hand, are often more concerned with outcome, as well as generation of theory, rather than testing it. Qualitative data are often very attractive to use as it offers rich information, although it may prove difficult to analyse (Miles, 1979).

This combination of methods is usually labelled *triangulation*, which is described by Bryman and Bell (2015) to “*combine the specificity and accuracy of quantitative data, with the ability to interpret characteristics and complex perceptions, provided by qualitative data*”. This implies that we will use one

method associated with a specific type of research, and cross-check our results with a method associated with another type of research.

We have made our choice of qualitative and quantitative methods, drawing inspiration from studies using similar methods, such as Stiles' (2001) study on the effect of the board of directors on the corporate strategy, although with some moderations. Our primary source of data will come from conducting a case study of Veidekke's project in Nydalen, which we will describe further down in the paper. During the case study, we will conduct interviews with a variety of key individuals, perform a questionnaire survey, as well as collecting data through participant observation.

The next sections will provide a more in-depth explanation of our choice of research design, as well as how we plan to approach the framework that we have established.

### ***5.1 Case Study***

A case study can be defined as a detailed analysis, focusing on a bounded system or situation (Bryman & Bell, 2015). It is a common research design, appearing to be quite popular in the business environment. A case study will provide us with the opportunity to study the totality of a complex phenomenon such as a construction project. According to Yin (2015), a case study is most relevant if the questions one wishes to answer is about "how" and "why" some phenomena work. The same applies for questions that require a thorough description. We believe that this makes case study the most appropriate research method to illuminate the experiences regarding the use of BIM kiosks.

At the same time, we believe that a case study is a suitable option considering our choice to use the triangulation method, with a combination of qualitative and quantitative methods. This due to Knights & McCabe's (1997) observation, where they suggest that "*a case study provides a vehicle through which several qualitative methods can be combined, thereby avoiding too great reliance on one single approach*".

According to Bryman & Bell (2015), researchers should choose cases where they expect learning will be the greatest. Eisenhardt & Graebner (2007) states that the case or cases should be selected for their suitability in enlightening certain constructs, as well as their likelihood of offering theoretical insight. For our case study, we have chosen to analyse one of the projects conducted by the Norwegian contractor Veidekke. Veidekke is one of Scandinavia's largest contractors and property developers, who carries out all types of construction projects (Veidekke, 2018). The case study will focus on one of the ongoing projects of Veidekke in Oslo. The large project includes hotels, a large cinema centre, several business premises, 149 apartments, as well as a kindergarten spread over 60.000 square meters.

What makes this project especially interesting, is that it involves the use of BIM at different levels, ranging from intensive use to only a small exposure, during different parts of the project. Eisenhardt & Graebner (2007) stresses the importance of observing contrasting patterns in the data (e.g., high use and low use), which we believe Veidekke's project can provide. The project is complex, which makes the potential of BIM huge. We also consider this to be what Yin (1994) defined as a "typical" or "representative" case, which tends to exemplify an everyday situation or form of organization. Studying a typical case of some phenomenon may be a good platform to explore the mechanisms at work, often leading to numerous distinctive conclusions. Due to being in the early stages of our research, we are currently awaiting more in-depth information about the project.

## ***5.2 Primary Data***

In order to obtain rich information about our research object, we need primary data about the impact of BIM, and how it has affected the construction process at Veidekke. Primary data analysis is by Bryman & Bell (2015) defined as data we as researchers have collected, and that the one collecting the data conducts the analysis. In this stage, we will be performing interviews as well as partake in participant observation.

Eisenhardt & Graebner (2007) describes interviews as a highly effective way of generating intensive and detailed empirical data, even though the data in certain situations may be biased. There are many different interview styles which may be applied, however, we will be using semi-structured interviews. This is a style in which the interviewer has a series of more general questions in the form of an interview schedule, but may ask follow-up questions in response to what is seen as significant replies (Bryman & Bell, 2015). We believe that this choice of interview style will provide us with the structure to make the interview efficient, without leaving out important questions. At the same time the follow-up questions allows for the possibility to obtain more in-depth information on certain topics.

To be able to extract the necessary information, we will have to identify numerous key individuals, who are able to view the effects and implementation of BIM from diverse perspectives. It is important that the individuals that are chosen differs in their hierarchical levels and functional areas, in order to get a more complete picture (Eisenhardt & Graebner, 2007). As mentioned, we will also use another research method called participant observation. This refers to the collection of data while being an observant in a social setting. We believe that by observing the use of BIM in the execution phase, we will get a better understanding of its effects and how it is actually put into use.

As our source of quantitative data, we will also be conducting a questionnaire survey. This survey will be sent to individuals that are somehow affected by the implementation of BIM in the execution phase at Veidekke, which we need to identify. Our plan is to develop a questionnaire survey which provides clear answer options in order to map the use of BIM-kiosks, as well as the users' attitude and behaviour towards it. We would also like to add an option in which the respondents may elaborate on their answer, and write more freely. We believe that by providing clear answer options, the threshold for answering is lower, and at the same time it becomes easier to compare the answers. This questionnaire survey will be used to support our main findings, which occurs from our qualitative research.



### ***5.3 Secondary Data***

In addition to our primary data, we will also have access to different forms of secondary data. Secondary data occurs when we as researchers analyse data collected by someone else (Bryman & Bell, 2015). Documents and data that might prove useful are records from different meetings regarding the project in question. We will also search for data published by other institutions in order to get a better understanding of the technology in use, as well as an insight into previous research on the matter. The use and gathering of secondary data is often less time consuming and more cost efficient than primary data, however, it might also exist a lack of familiarity, as well as low control over the quality and research methods when obtaining these data (Bryman & Bell, 2015), which we need to be aware of.

### ***5.4 Validity and Reliability***

The importance of validity and reliability in a case study varies between different studies, according to how appropriate the researcher feel they are. Yin (1984) put much emphasis on these factors, while others like Stake (1995) didn't consider them at all. Often, research with a more qualitative standpoint tend to ignore the salience of these factors (Bryman & Bell, 2015).

According to Brink (1993) many qualitative researchers tend to avoid using the concepts of validity and reliability as a whole, and rather focus on other constructs. One of these constructs were created by Guba & Lincoln (1981), who chose to substitute the concept of reliability and validity, with the concept of "*trustworthiness*", which contained four different aspects. In 1985 Lincoln & Guba changed their initial definition, stating that trustworthiness are defined as credibility, transferability, dependability, and confirmability (Lincoln & Guba, 1985). Even if there is an ongoing discussion surrounding the use of validity and reliability in qualitative research, we chose to consider both as important factors. In the next sections, we will explain how we will work towards improving both elements.

According to Bryman & Bell (2015), validity is concerned with the integrity of the conclusions that are generated from the research. To firstly address the external validity, we have no interest in generalizing our findings. We are conducting a case study, in which we are interested in understanding the complexity of our chosen project. To improve our internal validity, we have chosen to use the triangulation method as mentioned earlier. By using this approach, we combine different methods that have non-overlapping weaknesses and strengths in order to provide better evidence (Brewer & Hunter, 1989).

Johnson (1997) also addresses two other types of validity which are important in qualitative research; descriptive validity and interpretive validity. The first refers to the accuracy in reporting descriptive information. We will address this by investigator triangulation, in which we will be two people present to observe both interviews and other encounters, and at the same time we will record our interviews. This might create uncertainty among our interview objects, however, we believe that the nature of our questions will provoke sensitive answers that might frighten the participants. We will of course ask our interview objects for permission before recording.

The second type mentioned by Johnson is interpretive validity, which refers to *“accurately portraying the meaning attached by the participants to what is actually being studied”*. We will address this by providing our interview-objects with a copy of the interview after it has been transcribed. By doing so we open up for dialog and make sure that our perception of their answer is correct. To further improve the validity of our research, it is important to do precise preparatory work to ensure quality when developing the questions for our questionnaire survey and interviews. It is also important that the questions are linked to the research question in the thesis.

In terms of reliability, it is described by Bryman & Bell (2015) as the question of whether the results of the study are repeatable. Brink (1993) states that reliability is *“concerned with the consistency, stability and repeatability, as well as the researcher’s ability to collect and record information accurately”*. Put simply, when there is high reliability, the research can be performed again by different individuals, which in turn will get the same result. This definition is more directed

towards reliability in a quantitative setting, and is difficult to achieve considering our choice of using a case study.

However, Golafshani (2003) argues that the term of reliability in qualitative research corresponds with what Lincoln & Guba (1985) termed “*dependability*”, which again has close ties to the term reliability in a quantitative setting. Dependability is a way of showing that the findings in our research are consistent with the raw data that we collected. The technique mentioned to establish dependability is called *inquiry audit* or *external audit*. This entails having another researcher not involved in the research process examine both the process and product of the research study. Due to the nature of our paper, the resources we have available, as well as the time limit before submission, we will not be able to perform an inquiry audit.

## **6. Motivation**

Both authors of this paper study Master of Science in business, with a major in Strategy at BI Norwegian Business School. We are both very interested in the intersection between business and IT. Writing about digitalization in the construction industry is therefore something we find very interesting. Especially because the industry is in the middle of a digitalization process driven by the BIM technology. BIM is something we found fascinating once we read more about it, and we look forward to learning more about BIM and its implications.

## 7. Timetable

January	<ul style="list-style-type: none"><li>• Hand in preliminary report by 15th.</li><li>• Continues search in literature</li><li>• Establish contact with Veidekke</li><li>• Get access to relevant data and information from Veidekke</li></ul>
February	<ul style="list-style-type: none"><li>• Process the information gained from Veidekke</li><li>• Complete the theoretical framework</li><li>• Formulate the interviews</li><li>• Get an overview of relevant interview objects</li></ul>
March	<ul style="list-style-type: none"><li>• Conduct the interviews</li><li>• Conduct the participant observation</li><li>• Conduct the survey</li><li>• Analyze the information gained from the interviews, survey and observation</li></ul>
April	<ul style="list-style-type: none"><li>• Continue analyze the information gained from interviews, survey, and observation</li><li>• Start writing the thesis</li></ul>
May	<ul style="list-style-type: none"><li>• Continue writing the thesis</li><li>• Improve language and context</li><li>• Complete the master thesis</li></ul>
June	<ul style="list-style-type: none"><li>• Hand in the master thesis</li></ul>

# References

## *Articles*

Akhlaghpour, S., Wu, J., Lapointe, L., & Pinsonneault, A. (2013). The ongoing quest for the IT artifact: Looking back, moving forward. *Journal of Information Technology*, 28(2), 150-166.

Atkinson, A. (1998). Human error in the management of building projects. *Construction Management & Economics*, 16(3), 339-349.

Brink, H. I. L. (1993). Validity and reliability in qualitative research. *Curationis*, 16(2), 35-38.

Brodie, J., & Perry, M. (2001). Designing for mobility, collaboration and information use by blue-collar workers. *ACM SigGroup Bulletin*, 22(3), 22-27.

Bråthen, K., & Moum, A. (2015). Bridging the gap: taking BIM to the construction site. In *Proceedings of the 32nd CIB W78 Conference*.

Davies, R., & Harty, C. (2013). Implementing 'Site BIM': a case study of ICT innovation on a large hospital project. *Automation in Construction*, 30, 15-24.

Eisenhardt, K. M., & Graebner, M. E. (2007). Theory building from cases: Opportunities and challenges. *Academy of management journal*, 50(1), 25-32.

Gioia, D. A., Thomas, J. B., Clark, S. M., & Chittipeddi, K. (1994). Symbolism and strategic change in academia: The dynamics of sensemaking and influence. *Organization science*, 5(3), 363-383.

Golafshani, N. (2003). Understanding reliability and validity in qualitative research. *The qualitative report*, 8(4), 597-606.

Greiner, L. E., & Bhambri, A. (1989). New CEO intervention and dynamics of deliberate strategic change. *Strategic Management Journal*, 10(S1), 67-86.

Hammer, M. (1990). Reengineering work: don't automate, obliterate. *Harvard business review*, 68(4), 104-112.

Harstad, E., Lædre, O., Svalestuen, F., & Skhmot, N. (2015). How tablets can improve communication in construction projects. *Proceedings of IGLC 23, Perth, Australia*.

Hewage, K. N., & Ruwanpura, J. Y. (2006). Carpentry workers issues and efficiencies related to construction productivity in commercial construction projects in Alberta. *Canadian Journal of Civil Engineering*, 33(8), 1075-1089.

Hewage, K. N., Ruwanpura, J. Y., & Jergeas, G. F. (2008). IT usage in Alberta's building construction projects: Current status and challenges. *Automation in construction*, 17(8), 940-947.

Hopkins, W. E. (1987). Impacts of radical strategic change and radical strategic events on corporate culture, *American Business Review* 5(2): 42–48.

Hsiao, R. L., & Ormerod, R. J. (1998). A new perspective on the dynamics of information technology-enabled strategic change. *Information Systems Journal*, 8(1), 21-52.

Johnson, R. B. (1997). Examining the validity structure of qualitative research. *Education*, 118(2), 282.

Knights, D., & McCabe, D. (1997). 'How would you measure something like that?': Quality in a retail bank. *Journal of Management Studies*, 34(3), 371-388.

Laplante, A. (1991). Resistance to change can obstruct computing strategy. *InfoWorld*, 13(23), S59-S63.

Loveman, G. W. (1994). An assessment of the productivity impact of information technologies. *Information technology and the corporation of the 1990s: Research studies*, 84-110.

- Miles, M. B. (1979). Qualitative data as an attractive nuisance: The problem of analysis. *Administrative science quarterly*, 24(4), 590-601.
- Murvold, V., Vestermo, A., Svalstuen, F., Lohne, J., & Lædre, O. (2016). Experiences from the use of BIM-stations. *Proceedings of IGLC 24, Boston, USA, 20-22 Jul 2016*.
- North, D. C. (1991). Institutions. *Journal of economic perspectives*, 5(1), 97-112.
- Orlikowski, W. J. (2007). Sociomaterial practices: Exploring technology at work. *Organization studies*, 28(9), 1435-1448.
- Orlikowski, W. J., & Scott, S. V. (2008). 10 sociomateriality: challenging the separation of technology, work and organization. *Academy of Management Annals*, 2(1), 433-474.
- Peng, M. W., Sun, S. L., Pinkham, B., & Chen, H. (2009). The institution-based view as a third leg for a strategy tripod. *The Academy of Management Perspectives*, 23(3), 63-81.
- Rajagopalan, N., & Spreitzer, G. M. (1997). Toward a theory of strategic change: A multi-lens perspective and integrative framework. *Academy of management review*, 22(1), 48-79.
- Reich, A., Rooney, D., & Hopwood, N. (2017). Sociomaterial perspectives on work and learning: sites of emergent learning. *Journal of Workplace Learning*, 29(7/8), 566-576.
- Ruwanpura, J. Y., Hewage, K. N., & Silva, L. P. (2012). Evolution of the i-Booth© onsite information management kiosk. *Automation in Construction*, 21, 52-63.
- Stiles, P. (2001). The impact of the board on strategy: An empirical examination. *Journal of Management Studies*, 38(5), 627-650.

Tidd, J., Bessant, J., & Pavitt, K. (2005). *Managing innovation integrating technological, market and organizational change*. John Wiley and Sons Ltd.

Wagner, E. L., Newell, S., & Piccoli, G. (2010). Understanding project survival in an ES environment: a sociomaterial practice perspective. *Journal of the Association for Information Systems*, 11(5), 276.

Wiersema, M. F., & Bantel, K. A. (1992). Top management team demography and corporate strategic change. *Academy of Management journal*, 35(1), 91-121.

### **Books**

Baily, M. N., & Chakrabarti, A. K. (2011). *Innovation and the productivity crisis*. Brookings Institution Press.

Brewer, J., & Hunter, A. (1989). *Multimethod research: A synthesis of styles*. Sage Publications, Inc.

Bryman, A., & Bell, E. (2015). *Business research methods*. Oxford University Press, USA.

Börner, T., & Verstegen, B. (2011). Change within Institutional Theory: Building a Framework of Coping with Change.

Davenport, T. H. (1993). *Process innovation: reengineering work through information technology*. Harvard Business Press.

Guba, E. G., & Lincoln, Y. S. (1981). *Effective evaluation: Improving the usefulness of evaluation results through responsive and naturalistic approaches*. Jossey-Bass.

Hardin, B., & McCool, D. (2015). *BIM and construction management: proven tools, methods, and workflows*. John Wiley & Sons.



Huang, A. L., Chapman, R. E., & Butry, D. T. (2009). Metrics and tools for measuring construction productivity: Technical and empirical considerations. *Special Publication (NIST SP)-1101*.

Lincoln, Y. S., & Guba, E. G. (1985). *Naturalistic inquiry* (Vol. 75). Sage.

Morton, M. S. S. (Ed.). (1991). *The corporation of the 1990s: Information technology and organizational transformation*. Oxford University Press on Demand.

Pettigrew, A. (1988). *The management of strategic change*. Wiley-Blackwell.

Stake, R. E. (1995). *The art of case study research*. Sage.

Yin, R. K. (1984). Applied social research methods series Case study research: Design and methods.

Yin, R. (1994). Case study research: Design and methods. Beverly Hills.

Yin, R. K. (2015). *Qualitative research from start to finish*. Guilford Publications.

### ***Reports***

National Research Council. (2009). *Advancing the competitiveness and efficiency of the US construction industry*. National Academies Press.

### ***Web pages***

Cant, D. (2014, September 02). Architects – How Much Money is BIM Saving You? Retrieved January 12, 2018, from <http://www.veritas-consulting.co.uk/how-much-money-is-BIM-saving-you>

Veidekke (2018, January 05). Fakta om Veidekke. Retrieved January 10, 2018, from <http://veidekke.no/om-oss/article8949.ece>